

**WORKING AGREEMENT  
-BETWEEN-  
CH2M-WG IDAHO, LLC  
-AND-  
UNITED STEEL, PAPER AND FORESTRY,  
RUBBER, MANUFACTURING, ENERGY,  
ALLIED INDUSTRIAL AND SERVICE  
WORKERS INTERNATIONAL UNION,  
AFL-CIO,  
  
ON BEHALF OF  
  
LOCAL NO. 652**



**Effective April 30, 2007  
Through  
May 2, 2010**

## TABLE OF CONTENTS

1.	RECOGNITION .....	1
2.	UNION SECURITY .....	7
a.	CHECK-OFF AUTHORIZATION .....	9
3.	MANAGEMENT RIGHTS .....	10
4.	EMPLOYEE DUTIES RESPONSIBILITIES .....	11
5.	HOURS OF WORK AND WORK SCHEDULES .....	14
6.	OVERTIME .....	19
7.	SENIORITY .....	27
8.	PROMOTIONS, DEMOTIONS, TRANSFERS, LAYOFFS, TERMINATIONS AND REEMPLOYMENT .....	31
9.	WAGES AND CLASSIFICATIONS .....	41
10.	SHIFT DIFFERENTIAL .....	43
11.	HOLIDAYS .....	44
12.	PREMIUM PAY .....	46
13.	SECURITY PLAN AND BENEFITS .....	49
14.	LEAVE OF ABSENCE FOR UNION BUSINESS .....	50
15.	GRIEVANCE PROCEDURE .....	52
16.	UNION COMMITTEE AND EMPLOYEE REPRESENTATION .....	55
17.	BULLETIN BOARDS.....	58
18.	APPRENTICESHIP PROGRAM.....	59

19.	HEALTH AND SAFETY.....	61
20.	MISCELLANEOUS .....	64
21.	VALIDITY .....	73
22.	TERM OF AGREEMENT.....	74
	SIGNATURE PAGE .....	75
	EXHIBIT "A" WAGE/CLASSIFICATION.....	77
	EXHIBIT "B" PROMOTION AND DEMOTION CHART .....	79
	D&D AGREEMENT	
	MEMORANDUMS OF AGREEMENTS	
	CALENDARS	

This Agreement between CH2M-WG IDAHO, LLC (hereinafter called the “Company”) and UNITED STEEL, PAPER AND FORESTRY, RUBBER, MANUFACTURING, ENERGY, ALLIED INDUSTRIAL AND SERVICE WORKERS INTERNATIONAL UNION, AFL-CIO on behalf of Local No. 652 (hereinafter called the “Union”), WITNESSETH:

## **ARTICLE 1.**

### **RECOGNITION**

**1.1. Company Recognition of the Union.** CH2M-WG IDAHO, LLC (hereafter referred to as the Company) recognizes the UNITED STEEL, PAPER AND FORESTRY, RUBBER, MANUFACTURING, ENERGY, ALLIED INDUSTRIAL AND SERVICE WORKERS INTERNATIONAL UNION, AFL-CIO on behalf of Local No. 652 (hereafter referred to as the Union) as the exclusive collective bargaining agent with respect to wages, hours, and working conditions for the employees in the following described bargaining units at the Department of Energy (DOE) Project near Arco, Idaho: (In case of a discrepancy between any unit definition in this agreement and a definition contained in the pertinent NLRB order, the definition in the NLRB order will be controlling).

**1.1.1. Operations and Maintenance.** Operations and Maintenance employees at the IRC and associated buildings in Idaho Falls; internal moves in and between Company controlled facilities in Idaho Falls; Base Freight run as currently performed by OCAW; and onsite facilities within the responsibility and jurisdiction of the Company (see Section 1.2 Exclusions).

**1.1.1.a.** All operating and maintenance employees of the employer at its Idaho Chemical Processing Plant, including Analytical Control Laboratory employees at the Chemical Processing Plant, (National Labor Relations Board Order of February 19, 1954, in Case No. 19-RC-1399).

**1.1.1.b. The SWEPP Operators.** The SWEPP operators (National Labor Relations Board, Case No. 27-RC-7480, voluntarily recognized on June 20, 1994), most recently changed to RWMC operators.

**1.1.1.c. Experimental Machine Shop Employees.** All Experimental Machine Shop employees at the Test Reactor Area at the employer's facilities at the Idaho National Engineering and Environmental Laboratory (INEEL) (formerly Idaho National Engineering Laboratory [INEL] near Arco, Idaho, (National Labor Relations Board, Case No. 19-RC-255 1).

**1.1.2. Telephone Operators.** All Telephone Operators at the employer's INEEL near Arco, Idaho, and the Idaho Falls, Idaho, switchboard operation, including part-time Operators, (National Labor Relations Board, Case No. 19-RC-1911).

**1.1.3. Printing and Reproduction Machine Operators.** All printing and reproduction machine operators in the Scientific and Technical Information Services (STIS) Department (formerly Technical Publications) at the employer's INEEL near Arco, Idaho, and at the Idaho Falls, Idaho, Printing and Reproduction Shop operations (National Labor Relations Board, Case No. 19-RC-2055).

**1.1.3.a.** All employees employed by the employer in the STIS Copy Centers at the INEEL Site near Arco, Idaho, and in Idaho Falls, Idaho (NLRB Case No. 19-RC-9216).

**1.1.4. Cafeteria Employees.** All cafeteria employees employed by the Company at the INEEL Site near Arco, Idaho, including part-time cafeteria employees (National Labor Relations Board, Case No. 19-RC-3620)

**1.1.5. Mail Clerk Employees.** All Mail Clerks employed by the Company in connection with its operation at the INEEL, Scoville, Idaho, and the Company facilities in Idaho Falls (National Labor Relations Board, Case No. 19-RC-4954).

**1.1.6. Photo/Video/ Image Processing and Micrographics Employees.** All employees in Company Photo/Video/Image Processing and Micrographics Units of the INL near Arco, Idaho, and in Idaho Falls, Idaho, (National Labor Relations Board, Case No. 19-RC-7100).

**1.1.7. Medical Division Employees.** All Nurses, Medical Technologists, X-Ray Technologists, and LPN Examining Technologists employed by the Company, within the INEEL Occupational Medical Program (formerly INEL Health and Occupational Medical) at its facilities located at the Department of Energy, INEEL Site near Arco, Idaho, and in Idaho Falls, Idaho, (National Labor Relations Board, Case No. 19-RC-9592).

**1.1.8. Radiation Control Technicians.** All Health Physics Technicians employed by the Company at its Idaho Chemical Processing Plant at the INEEL near Idaho Falls, Idaho. (National Labor Relations Board order of February 22, 1974, in Case No. 19-RC-6950).

**1.1.8.a.** All Radiation Control Technicians as certified by the National Labor Relations Board, January 23, 1995 Case No. 27-RC-75 15.

**1.1.9. Decontamination Technicians.** All Decontamination Technicians employed by the Company at its Idaho Chemical Processing Plant at the INEEL near Idaho Falls, Idaho. (Case No. 19-RC-7013 voluntarily recognized on March 12, 1974).

**1.1.10. Clothing Issue Technicians.** All Clothing Issue Technicians employed by the employer at its Idaho Chemical Processing Plant at the INEEL near Idaho Falls, Idaho. (National Labor Relations Board order of May 27, 1977, in Case No. 19-RC-8374).

**1.1.11. Vehicle Repair.** All Vehicle Repair employees classified as Vehicle Repair Specialists and Vehicle Repair Specialist Helpers in the Company Fleet Operations (formerly Fleet Management) area at the INEEL (National Labor Relations Board, Case No. 27-RC-7080).

**1.1.12.** The Company recognizes the Union as the exclusive collective bargaining agent with respect to wages, hours, and working conditions for Dosimetry Technicians located in the Dosimetry laboratory located at the Central Facility area at DOE's Idaho site as contained in the National Labor Relations Board Order of August 22, 2003, Case No. 27-RC-8264

**1.2. Exclusions.** The following employees are excluded from the units described in 1.1: Confidential, administrative, professional (excluding those Medical Division employees included within NLRB Case No. 19-RC-9592), office clerical employees, guards, and supervisors, as defined by the Act. It is intended that all those employees and their replacements that were excluded from the units above before the three Agreements (EG&G Master, EG&G Fleet Mechanics and WINCO CPP) were combined remain excluded and that by combining the three Agreements neither party has agreed to either extend or give up representation beyond those employees and their replacements previously not covered or covered by the three Agreements. The Experimental Machine Shop (Case No. 19-RC-255-1); Telephone Operators (Case No. 19-RC-1911); Medical Division Employees (Case No. 19-RC-9592) and Vehicle Repair (Case No. 27-RC-7080) are currently excluded from the CWI scope of work. Should they become part of the CWI scope of work, the Company will recognize and bargain with the Union for inclusion in this Agreement.

**1.3. Part-Time Employees.** It is agreed that the Company may employ part-time employees and that they are recognized for the purpose of collective bargaining.

**1.3.1.** It is understood the definition of part-time is an employee hired by the employer to work less than forty (40) hours per week.

**1.3.2.** It is agreed that the Company may employ part-time employees for work in connection with and needed to supplement regular, full-time employees during absences and for work load requirements. It is recognized that it is not the Company's intention to replace regular full-time employees/positions with part-time employees. The number of part-time employees will not exceed twenty percent (20%) in the Telephone, Cafeteria, Medical, Mail Room, or Custodian units. In units of less than five (5) employees, the limit shall be one (1) part-time employee. Additionally, the number of part-time employees in each of the other units shall not exceed six (6) employees (one [1] per area). Extensions of this limit will be mutually agreed upon by the Company and the Union.

**1.3.3.** During their employment, part-time employees shall accumulate unit seniority from the date of employment in their respective classification on a separate seniority list titled part-time seniority. Part-time employees will only have seniority among part-time employees in their respective classification. To fill a full-time bargaining unit position, qualified part-time employees in the classification will be offered the position. Part-time employees progressing to regular, full-time status will accumulate unit seniority on the full-time seniority list in their classification from the first full day of continuous employment as a regular, full-time employee.

**1.3.4.** In the event of resignation or termination for just cause, part-time employees are covered under all applicable procedures in the Working Agreement and grievance procedures.

**1.3.5.** In the event of reduction in force, a regular full-time employee may displace a part-time employee in his classification. When a part-time employee is laid



off, he will be covered by procedures in the Working Agreement, Article 8.3, Re-employment Following Layoff.

**1.3.6.** Part-time employees shall be eligible for participation in the security plans and benefits for part-time employees, in accordance with Article 13, Security Plans and Benefits.

**1.3.7.** Part-time employees shall receive the established base rates of pay for work which they perform. Part-time employees shall be credited with actual hours worked for determining base wage rate progression in accordance with Exhibit A.

**1.3.8.** Part-time employees shall not be eligible for overtime, temporary upgrades, or shift assignments until such time as the Company has exhausted all reasonable attempts to fill the assignment from full-time employees. Part-time employees shall receive overtime, holiday, or shift differential for work performed.

**1.3.9.** A part-time employee will accumulate one (1) hour of holiday straight time pay for every twenty-six (26) straight time hours worked (excluding overtime hours). Additionally, he/she will receive time and one-half (1 1/2) for all hours actually worked on a holiday including the applicable shift differential.

**1.3.10.** It is understood there shall be no pyramiding of overtime, holiday, and/or premium pay. If time worked falls under two (2) or more such categories, the higher rate shall prevail.

## ARTICLE 2

### UNION SECURITY

**2.1. Union Membership.** Union membership will be made available for employees of the Company employed in positions covered by this Working Agreement.

**2.2. Terms of Union Membership.** The Union will make membership in the Union available to all employees covered by this Agreement on a non-discriminatory basis.

**2.3. Deduction of Union Dues.** The Company agrees to deduct from the wages of employees covered by this Agreement, who authorize such deductions of their union dues, and to remit such dues within thirty (30) days of receipt to the Secretary-Treasurer of the International Union. In the event of a change in the amount of the union dues, the Company will deduct such changed amount only after thirty (30) days notice, in writing, to the manager of Labor Relations from the Secretary/Treasurer of the Local Union.

**2.3.1. Military Leave.** The Union and the Company agree that the Company will discontinue the deduction of Union dues for USW-represented employees while they are on active duty military leave. The Company also agrees to automatically reinstate the deduction of union dues as soon as the employee returns from active duty and is in active employee pay status.

**2.4. Company Protection from Liability.** Except where the Company has made a clerical error in the deduction for dues, which will be adjusted promptly by the Company, any questions as to the correctness of the amount deducted shall be settled between the employee and the Union; and the Union shall indemnify and save the Company harmless against any and all claims, payments, law suits, or other forms of liability that may arise out of or by reason of action taken by the Company at the direction of the Union in making

payroll deductions of Union membership dues. The Company shall not be required to take any action against an employee for electing not to become or remain a Union member.

**2.5. Union Solicitation.** The Union agrees there will be no solicitation of employees for Union membership on Company premises during working hours by the Union or its members.

**2.6. Notification of New Hires.** By the fifteenth (15th) of the month, the Company shall provide the Union a monthly listing of all new hires, transfers, and terminations to or from the bargaining units.

**2.7. Check-off Authorization.** The conditions controlling the deduction of Union dues are stated on the following Check-off Authorization Form. The Company will allow a Union representative to distribute a Check-Off Authorization form to a newly-hired represented employee.

**2.8. Dues Deduction.** Within the meaning of the dues deduction authorization, membership dues will include only that regularly required equally of all members who has been designated as membership dues pursuant to appropriate Union constitutions and by-laws.

**2.9. Federal Enclave.** In the event the DOE's Idaho site is designated as a federal enclave, the parties to this agreement will meet in a timely manner to discuss an Article 2 "Union Security" proposal from the Union.

CHECK-OFF AUTHORIZATION

Pursuant to this authorization and assignment, please deduct from my pay each week while I am in employment within the collective bargaining unit in the Employer, and irrespective of my membership status in the Union, dues, assessments and (if owing by me) an initiation fee each as designated by the International Secretary/Treasurer of the Union.

The aforesaid payment shall be remitted promptly by you to James D. English, or his successor, International Secretary/Treasurer of the United Steel, Paper and Forestry, Rubber, Manufacturing, Energy, Allied Industrial and Service Worker’s International Union, AFL-CIO, CLC (also known in short as the “Union”, “United Steelworkers” or “USW”) or its successor, Five Gateway Center, Pittsburgh, PA 15222.

This assignment and authorization shall be effective and cannot be cancelled for a period of one (1) year from the date appearing above or until the termination of the current collective bargaining agreement between the Employer and the Union, whichever occurs sooner.

I hereby voluntarily authorize you to continue the above authorization and assignment in effect after the expiration of the shorter of the periods above specified, for further successive periods of one (1) year from such date. I agree that this authorization and assignment shall become effective and cannot be cancelled by me during any such years, but that I may cancel and revoke by giving to the *Local Union and* appropriate management representative, of the facility in which I am employed, an individual written notice signed by me and which shall be postmarked or received by the *Local Union and* Employer within fifteen (15) days following the expiration of any such year or within fifteen (15) days following the termination date of any collective bargaining agreement between the Employer and the Union covering my employment if such date shall occur within one of such annual periods. Such notice of revocation shall become effective respecting the dues for the month following the month in which such written notice is given.

\_\_\_\_\_  
Date

\_\_\_\_\_  
Employee's Signature

\_\_\_\_\_  
Employee S#

## **ARTICLE 3**

### **MANAGEMENT RIGHTS**

The Union recognizes that managerial functions inherent in the conduct of business by an employer are retained by the Company. The management of the Company and direction of its employees except to the extent modified or deleted by this Agreement remain vested in the Company. Such rights of management include but are not limited to the following: the introducing of new or improved production means, methods, processes or equipment; verifying work has been performed correctly; determining the size and the composition of the work force; the establishment of work rules; discipline of employees for cause; and the hiring, reducing or increasing of the work force.

## ARTICLE 4

### EMPLOYEE DUTIES AND RESPONSIBILITIES

**4.1. Employee Supervision.** Each employee will be assigned work by one recognized supervisor and will be responsible to that supervisor for proper performance. Administrative matters such as personal leave requests may require notification of an administrative supervisor having administrative responsibility for the section.

**4.2. Reporting for Work.** When reporting to work, each employee will report at a place and time designated by his supervisor.

**4.3. Unavoidable Absences from Work.** Any employee who finds he will be unable to report for work when due will notify his supervisor or other designated person of his expected absence at least two (2) hours in advance whenever possible stating the reason or necessity for such absence. (Medical employees shall be required to give three [3] hours notice). The giving of notice does not insure that the absence will be approved or paid. It is the intention of the Company to administer this provision uniformly as consistent with the facts in each case.

**4.4. Complying with Established Work Rules.** Each employee will observe Company policies and prescribed rules regarding attendance, work performance, personal conduct, safety, radiological safety, security, and substance abuse. Employees should go to their first line supervision on questions pertaining to Company policies and prescribed rules.

**4.5. Work Assignments.** All employees are expected to perform such work as is incidental, usual, and necessary to safe and efficient operations. Incidental work, necessary to complete primary job assignments, will be performed if the employee is appropriately qualified to do such work. Employees will also perform such work as required in emergency conditions or for good housekeeping, including minor

maintenance to equipment utilized by bargaining unit personnel and running maintenance. Running maintenance, as used herein, when applied to operations employees, means minor maintenance necessary for efficient operation of equipment such as, but not limited to, tightening packing glands on pumps, valves, etc, but shall not include overhaul work.

**4.6. Additional Work Assignments.** Employees who are temporarily not needed to do their usual existing work may be required to perform other work for which they are qualified, with the objective of utilizing all available manpower effectively and economically. When all things are equal (such as, availability, qualifications, continuity) seniority will be the deciding factor for the assignment. Supervision will notify the appropriate Union representative when making assignments.

**4.7. Clarification of Work Sharing.** The parties recognize that there are distinguishable skills between various classifications. At the same time, it is agreed that there is work that, although traditionally assigned to specific classifications, can be performed safely, efficiently and economically by employees in other classifications. Such work would typically require no additional training or only nominal training which will be provided to those employees assigned to perform the work.

**4.8. Ceasing Work.** Where relief is scheduled, no employee shall cease work until his relief begins work or until released by his supervisor.

**4.9. Cooperation in Jobs, Methods, Personnel, and Performance.** The Workmen's Committees and/or employees will furnish information to the Company concerning their work and cooperate with and assist the Company in formulating, establishing and maintaining, and/or applying programs or job analysis, job evaluation, job instruction, improved job methods, personnel evaluation, safety, training, performance tests, qualifications, certifications, and re-certifications.

**4.10. Maintaining Certifications/Qualifications/Licensing.** Employees will be required to maintain certifications/qualifications/ licensing to meet operational needs. It is recognized by both the Company and the Union that operational training and skill requirements are subject to change as business practices, technology, plant modifications, and applicable regulations affect work performed under the Working Agreement. Significant changes will be discussed with the Union. The Company will provide appropriate training with equal opportunity over a reasonable amount of time to allow employees to remain certified/qualified/licensed to perform work within their classifications. Employees will be required to participate in training programs and maintain certification/qualification/licensing requirements. The Company will pay 100% of all costs associated with Certification/Qualifications/Licenses required by State or Federal Law.

Employees who fail to certify/recertify/qualify/re-qualify or maintain their license will be demoted in accordance with Section 8.2.2.



## ARTICLE 5

### HOURS OF WORK SCHEDULES

**5.1. Hours of Work.** Each employee will have an established work schedule that complies with this Article. Changes to the established schedules will be discussed with affected employees, and the Union will be given the opportunity to provide alternatives.

When at the Company's direction, an employee works through their regular unpaid lunch period, that employee shall be compensated for one-half (1/2) hour at the overtime rate of one and one-half (1 1/2) times their regular base wage rate and allowed adequate time to eat their lunch later in their regular shift.

**5.1.1. Work Week.** The work week for all employees starts at 12:01 a.m. on Monday and ends seven (7) days later.

**5.1.1.a.** The work week for off-site employees working the 9x80 schedule will start at noon on Friday and end seven (7) days later on Friday noon.

**5.1.2. Work Day.** The work day starts at 12:01 a.m. and ends twenty-four (24) hours later.

**5.1.3. Posting Work Schedules and Change Notification.** Current schedules of work for all employees shall be posted by the Company. In the event of a change in schedule, the employee shall be notified in writing, if practical. Otherwise, the employee shall be notified verbally and acknowledge such notification, with written confirmation as soon thereafter as practical.

**5.2. Work Schedules for Day Workers.**

**5.2.1. Standard Work Schedules.** The standard work schedule will be one of the following:

**5.2.1.1. 5x8 Schedule.** This schedule will be Monday through Friday inclusive. Workers will be scheduled for eight and one-half (8 1/2) hours with a thirty (30) minute unpaid lunch period. Start times will be between 6 a.m. and 10 a.m. Release times will be eight and one-half (8 1/2) hours later, between 2:30 p.m. and 6:30 p.m.

**5.2.1.2. 4x10 Schedule.** This schedule will be four (4) consecutive days either Monday through Thursday or Tuesday through Friday. Workers will be scheduled for ten and one-half (10 1/2) hours with a thirty (30) minute unpaid lunch period. Start times will be between 6 a.m. and 10 a.m. Release times will be ten and one-half (10 1/2) hours later between 4:30 p.m. and 8:30 p.m.

**5.2.2. Alternate Work Schedules.** In order to meet the business needs of a competitive marketplace and to adapt to the needs of an increasingly diverse work force, schedules other than those described in Section 5.2.1 may be implemented. Before being implemented, such schedules will be discussed with the Union and Labor Relations to ensure contract items (meal periods, overtime, holidays, etc). are properly addressed. The possible options are numerous and can not be anticipated in all cases. However, the attributes of such schedules can be described as:

**5.2.2.1. Work Days.** The alternative work schedule will be composed of four (4) or five (5) days.

**5.2.2.2. Scheduled Off Days.** The alternative work schedule will normally contain no less than two (2) consecutive scheduled days off.

**5.2.2.3. Work Hours.** The alternative work schedule will normally contain forty (40) regularly scheduled hours with no more than twelve (12) and no less than four (4) hours in any work day.

**5.2.2.4. Meal Period.** Thirty (30) minutes or one (1) hour unpaid meal periods will normally be provided on any alternative work schedule.

### **5.3. Work Schedules for Shift Workers**

**5.3.1. Requirements for Shift Work.** The seven day operations at the Site require employees to work schedules to support those operations.

**5.3.2. Types of Shifts.** An employee may be assigned to any of these shift schedules to support Site operational activities.

**5.3.2.a. Rotating Shifts.** Where an employee rotates on an eight (8) hour schedule between the day, evening, and night shifts, or where an employee rotates on a twelve (12) hour schedule between the day and night shift.

**5.3.2.b. Fixed Shifts.** Where an employee works a steady shift other than days.

**5.3.2.c. Alternating Shifts.** Where an employee alternates between two (2) shifts.

### **5.3.3. Rotating Shift Work Schedule.**

**5.3.3.a. Rotating Eights (8's).** Normally the day shift will be from 8:00 a.m. until 4:00 p.m.; the evening shift will be from 4:00 p.m. until 12:00 midnight; the night shift will be from 12:00 midnight until 8:00 a.m.

**5.3.3.b. Rotating Twelve's (12's).** Normally the day shift will be from 7:00 a.m. to 7:00 p.m. and the night shift will be from 7:00 p.m. until 7:00 a.m..

**5.3.3.c. Work Weeks.** For rotating eights (8's), work weeks will normally contain consecutive work days and be based on forty (40) hours, Monday through Sunday inclusive. For rotating twelve's (12's), work weeks will normally contain consecutive work days and be based on either forty-eight (48) hours or thirty-six (36) hours Monday through Sunday. Days off will be scheduled on consecutive days whenever possible.

**5.3.4. Shift Worker Meal Break.** As business needs allow, shift workers working twelve (12) hour shift will be allowed reasonable time to eat every four (4) hours, but not to exceed two (2) meal breaks per shift. Other shifts will be allowed one meal break near the middle of the shift.

#### **5.4. Schedule Changes**

**5.4.1. Premium Pay for Short Notice.** When an employee's schedule is changed, and at least forty-eight (48) hours notice prior to the time he is to report for work on the new schedule is not given, the employee shall receive pay for the time worked on the first shift of the rearranged schedule at the rate of one and one half (1 1/2) times his regular base wage rate. This provision does not apply in cases of promotion (to the employee promoted) or when schedule changes to suit the personal convenience of one or more employees are permitted.

Premium pay under this clause shall not be paid for a rearranged schedule to the extent the change in schedule results in overtime or for work performed subject to the holiday premium.

**5.4.2. Pyramiding.** In no case will any premium pay, including overtime, be pyramided.

**5.4.3. Changes Between 8, 10, or 12 Hour Schedules.** The Company will make every reasonable effort to schedule work in such a manner that the moving of personnel between the 8, 10, or 12 hour schedules is made in full week increments whenever practicable, and to avoid such moves during weeks containing holidays. In the event a mid-week schedule change occurs in/out of the 8, 10, or 12 hour schedules, the affected employee will be paid one and one-half (1 1/2) times his base wage rate for the first such change in the work week. Premium pay will not be paid for a subsequent change within the same work week to return to his original schedule.

This premium shall not be paid to an employee who is notified of a schedule change prior to beginning the series of consecutive shifts that define his work week.

**5.4.4. Schedule Change at Request of Company.** No employee shall lose any scheduled time or pay within the work week (exclusive of shift differential), by reason of having worked overtime or by reason of shift or schedule changes made at the request of the Company. Normally an employee's scheduled days off within the work week will not be changed after the employee has started work on his schedule for that work week.

**5.4.5. Premium Pay for Less Than Twelve Hours Between Shifts.**

Employees will receive one and one half (1 1/2) times the base rate of pay for the time worked on the first shift of the rearranged schedule when the company fails to allow at least twelve (12) hours off between shifts. This provision does not apply in cases of promotion (to the employee promoted), shift changes created by employees exercising bid rights, as per Article 8, Section 8.12, or shift changes made at the request of one or more employees.

**5.5. Reporting.** Each employee will arrive at his post of duty sufficiently in advance of shift change that he may prepare himself to assume his job responsibilities at the time appointed for his shift to begin.

## ARTICLE 6

### OVERTIME

**6.1. Overtime Rates.** Overtime rates, computed at one and one-half (1 1/2) times the sum of the regular base rate, shall be paid in lieu of regular wages for work performed by an employee in excess of forty (40) hours in any work week (thirty-six [36] hours scheduled work week for 12-hours rotating shifts). Unpaid leave shall not be counted as time worked for the purpose of computing overtime. "Regular base rate" for overtime pay purpose shall be the rate applicable to the particular work performed during the overtime period. For the purpose of computing fractional overtime hours worked, such overtime shall be computed to the nearest thirty (30) minutes.

**6.2. Work on Scheduled Days Off.** All hours worked by an employee on his scheduled days off shall be paid by the Company at one and one-half (1 1/2) times his hourly rate of pay subject to the 40-hour requirement in Section 6.1.

**6.3. Required Time-Off to Avoid Overtime.** No employee shall be required to take time off during his scheduled work week to avoid the payment of overtime.

#### **6.4. Overtime Records**

**6.4.1. Recording and Posting Overtime Hours.** A current record of overtime accumulated by each employee will be maintained. Area overtime rosters incorporating the records of area employees will be posted in the appropriate work locations. For the purpose of such overtime accumulation records, overtime assigned or offered will be considered the same as if accepted and worked. Only hours worked or offered outside an employee's regular schedule will be credited to his overtime record but in no case will the employee be charged for more than the actual hours worked on the overtime assignment, except as provided in 6.7.10. An employee may request in writing to be automatically charged for overtime refusal without notification. This request remains in effect until withdrawn.

**6.4.2. Transferring Overtime Hours.** New employees, including recalled employees, and those promoted, demoted, transferred (regular or temporarily) to another area or classification will be credited with the average overtime hours accumulated by all employees in the classification in the respective area. This will occur within the first full shift. An employee on temporary assignment who completes the week will remain on that area overtime roster until the end of the work week. Upon returning to his assignment, such employee's overtime record shall include all overtime hours worked during the temporary assignment.

**6.5. Pyramiding of Premium and/or Overtime Pay.** Overtime or premium payment for any hour worked eliminates that hour from consideration for payment on any other basis. If time worked falls under two or more overtime and/or premium pay classifications, the higher rate shall prevail.

**6.6. Eligibility**

**6.6.1. Overtime for Temporary, Part-Time, and Probationary Employees.** Except in emergencies, temporary hires, part-time or probationary employees will not be eligible for overtime assignments in their work area until all regular employees in the area have been offered the overtime assignment. For the purposes of administration of the Section, an emergency shall be defined as a situation which is a potential health or safety problem, or work which requires immediate attention and all readily available manpower.

**6.6.2. Overtime Eligibility for Employees on Temporary Upgrade.** An employee on temporary upgrade will be eligible for overtime assignments in that classification immediately upon upgrade. Once such employee is eligible for overtime assignment in the upgrade classification, he will not be eligible for an overtime assignment in his regular classification until he returns to work his regular classification.

## **6.7. Overtime Distribution**

**6.7.1. Overtime Groups.** There are defined overtime groups. An example of an overtime group is all Electricians within an area. Overtime will be distributed within a classification within an area.

**6.7.2. Overtime Adjustments.** When it has been agreed by the Company and the Union that a qualified employee has been improperly by-passed for an overtime assignment on a particular overtime roster the Company will remedy it as follows:

With each individual overtime roster, when there is an improper assignment of overtime on an overtime roster, up to four (4) times over a thirty-six (36) month period beginning with contract ratification, the affected employee(s) will be offered the next available overtime assignment the employee is qualified to work. The employee will have the opportunity to either work the assignment or turn it down and the matter will be considered resolved. The actual hours worked will be paid.

If an improper assignment of overtime on a particular overtime roster occurs a fifth (5th) time within the thirty-six month period the affected employee(s) will be compensated in the amount he would have earned had the proper assignment been made. Occurrences beyond the fifth (5th) one will be handled in this same manner.

An improper overtime assignment made by a represented employee being utilized under 6.7.16 will not be counted under this provision.

**6.7.3. Overtime Volunteer List.** There will be a weekly overtime volunteer list posted for each classification within an area. Employees desiring overtime work during that week will sign the weekly overtime volunteer list and indicate the day(s) they are available for overtime assignments and the amount of overtime hours accumulated at the time of signing. A sign-up cutoff time will be established for each overtime roster, with input from those on the roster. An employee may request in writing to be automatically charged for overtime refusal without the overtime being offered. The



request remains in effect until withdrawn.

**6.7.4. Assignments from the Volunteer Overtime List.** The Company will initially assign overtime hours to the employees who have signed the weekly volunteer overtime list on the days the employees have indicated availability. Initial assignments will be made to those employees with the lowest amount of accumulated overtime. Where overtime hours are equal, seniority will prevail.

**6.7.5. Overtime Requirements in Excess of Available Volunteers.** In the event the Company's overtime requirement exceeds the available volunteers or if there are no volunteers, the Company may assign the overtime to be worked, beginning with the employee who has accumulated the least amount of overtime hours.

**6.7.5.1. Overtime Assignment.** Beginning with the lowest accumulated hours, overtime assignments will be made in the order of (1) Volunteer, (2) No Preference and then (3) Refusal. If management agrees, an employee at work assigned overtime may find a qualified substitute who is at work to cover the overtime and overtime assignments made in accordance with this substitute provision are exempt from the grievance and arbitration process.

**6.7.6. Zeroing Overtime Records.** Unless otherwise provided, effective the first week of each calendar year, all employee overtime rosters shall be reduced by the number of hours of the low person in each classification. The parties agree to readdress overtime issues relative to spread at the start of each calendar year. If issues remain, a Memorandum of Understanding will be negotiated.

**6.7.7. Overtime Assignments With More Than Three (3) Hours Notice.** If the overtime assignment is offered at least three (3) hours in advance of an overtime requirement, the overtime assignment shall be made to the employee who has signed the weekly volunteer overtime list who has the least amount of overtime, whether or not the employee is at work.

**6.7.8. Overtime Assignments With Less Than Three (3) Hours Notice.** If the overtime assignment is not offered at least three (3) hours in advance of an overtime requirement, the assignment may be made to the employee at work who has signed the weekly volunteer overtime list and who has the least amount of overtime in the job classification.

**6.7.9. Overtime Volunteer Availability Required.** If an employee signs the weekly volunteer overtime list indicating his availability on his days off or off duty hours, he must be available upon notification to report for work on an overtime assignment.

**6.7.10. Overtime Volunteer Non-availability Penalty.** If an employee signs the weekly volunteer overtime list and refuses an assignment or is not available to be reached, the employee will be charged double the actual hours worked.

**6.7.11. Special Overtime Requirements.** It is recognized that certain jobs may require special crew assignments and/or job continuity and the assigned personnel may continue with the overtime assignment. Supervision will notify the appropriate Union representative when making the assignment.

Employee(s) will work the overtime to maintain project continuity based on shop assignment.

**6.7.12. Weekly Overtime Limits.** No employee shall be permitted to work more than seventeen (17) consecutive hours, nor more than twenty-seven (27) hours in any forty-eight (48) hour period, nor more than seventy-two (72) hours in any seven (7) day period, and for twelve (12) hour shift workers, within twelve (12) hours of a scheduled twelve (12) hour shift. Employees shall not be forced to work more than sixty-four (64) hours in a work week or more than fourteen (14) consecutive days without having two (2) consecutive days off. Consistent with the above limitations, a 4 x 10 day worker will not be forced to work more than 12 hours in a work day more often than once during the normally scheduled work week (midnight Sunday through midnight

Thursday). These limits will not apply in unusual or critical circumstances.

**6.7.13. Unqualified Employees.** An employee may be bypassed for an overtime assignment if he is not qualified to perform overtime work due to physical limitation or illness, radiation exposure, lack of qualification/certification, etc.

**6.7.14. Overtime for Union Officers.** Union officers (i.e., President, Vice President, Workmen's Committee representative, Trustee and Secretary) shall not be charged for overtime refusals when such refusals are necessitated by the officer's scheduled attendance at Union meetings, executive board meetings and/or Workman's Committee meetings. This provision shall not be construed to release a Union official from the obligation to work when a forced overtime situation occurs.

**6.7.15. Overtime Prior to Vacation or Scheduled Shift.** The Company shall not require an employee to work overtime after his last scheduled shift prior to going on vacation. The Company also agrees that vacation continues up to the start of the employee's first scheduled shift of work following a vacation. During this time off, the employee shall not volunteer to work overtime on his scheduled vacation (Personal Leave) day(s) but may volunteer to work the other days.

The parties agree to address the handling of overtime during the curtailment prior to each curtailment period.

**6.7.16. Administering Overtime.** The Company may from time to time utilize represented employees to assist with overtime assignments. If the administration of overtime is to be handled by a represented employee, he shall be upgraded to lead for the time actually worked performing this function, and shall be computed to the nearest thirty (30) minutes.

**6.7.17. Overtime Assignments, Idaho Falls.** Employees working in town will be bypassed on Site overtime, unless additional persons are needed. Also, Site

personnel will be bypassed on town overtime unless additional persons are needed.

## **6.8. Furnishing Meals**

**6.8.1. Provisions for Furnishing Meals.** An employee who works more than two (2) hours immediately preceding his regularly scheduled shift starting time or who works more than two (2) hours beyond his regularly scheduled shift shall be furnished a meal and allowed to eat the same on Company time. Where an employee continues to work more than eight (8) hours beyond his regularly scheduled shift he shall be furnished an additional meal and allowed to eat the same on Company time. However, an employee who works the full night shift and continues to work the day shift (two [2] consecutive shifts) will, at his request, be furnished not more than two (2) meals. The cost of each meal furnished to an employee under the provisions of this Section 6.8.1 shall not exceed \$7.00. (In May of each year, the Company will review the cost of meals and determine if an increase in this meal allowance is warranted). If operational duties prohibit the employee from leaving the job to eat a meal, a meal shall be brought to him, if available. Where reasonably available, a hot meal will be provided. Employees who are eligible for a meal while working in off-Site areas will be reimbursed up to \$7.00 upon presentation of a satisfactory receipt.

**6.8.2. Employees Held Over Four or More Hours.** Where an employee working on his scheduled shift is held over from the scheduled shift to work four (4) or more hours on the following shift, such employees shall be provided the option of spending the rest time at the Site and being furnished two (2) additional meal tickets or utilizing transportation in accordance with the Company's current practices.

**6.8.3. Employees Called Out Prior to Scheduled Shift.** When an employee is called out prior to his regular scheduled shift chooses to spend the remaining unpaid time until his scheduled shift begins at the Site, he shall be furnished two (2) meal tickets.

**6.8.4. Intent of Company Furnished Meals.** The furnishing of meals

referenced above is intended to cover only those employees who are unable to furnish their own meals as opposed to furnishing meals to employees who know about the overtime before they come to work and can reasonably be expected to provide their own meals.

**6.9. Sleeping Accommodations.** If sleeping accommodations or transportation to either the employee's home or personal vehicle can not be provided, said employee will not be forced to remain at work for overtime.

**6.10** In assigning D&D overtime at INTEC and RWMC, the Company will consider specific skills in making those assignments.

D&D workers and other classifications may be assigned to the same overtime roster.

Subcontract RCT employees will not be offered overtime assignments until all available represented RCT's within a specific overtime roster have been offered and/or refused the assignment.

## ARTICLE 7

### SENIORITY

**7.1. Seniority Described.** Seniority, as used in this Agreement, is the measure of an employee's length of service and shall apply with respect to promotions, demotions, layoffs, bidding shift assignments, and reemployment.

**7.2. Probationary Period.** During the first ninety (90) calendar days of employment in the bargaining unit, an employee shall be considered on probation insofar as continued employment with the Company is concerned (thirty [30] calendar days for a temporary employee who becomes a permanent employee). The probationary period may be extended to a total of one hundred thirty-five (135) calendar days upon mutual agreement of both parties. In all cases, termination of an employee's service prior to the expiration of the probationary period shall not be subject to arbitration.

**7.3. Seniority Roster.** The Union is responsible for all determinations related to the seniority rights and standings of its membership. The Company will provide information to assist the Union in making seniority determinations. Within thirty (30) days of the execution of this contract and every six (6) months thereafter, the Union will prepare a seniority roster and distribute it for publication to the Company. Any Union member disputing his or her seniority standing, as shown on the published seniority roster, may file a complaint with the Union, within thirty (30) days of the date of publication. The Union agrees to indemnify the company for all claims and costs related to actions taken by the Company in reliance upon the published seniority roster.

**7.4. Types of Seniority.** It is agreed that past length of service is properly reflected in the current seniority standings of the employees as of the effective date of this Working Agreement. Subsequent to the effective date of this Working Agreement there shall be two types of seniority: unit seniority or unit and section seniority.

**7.4.1. Unit Seniority.** The length of service on a regular, full time basis in the bargaining unit referred to as the Operations and Maintenance Unit. All represented employees' seniority will be listed in the bargaining unit. Unit seniority shall begin with the first full day of work performed on a regular, full time basis in the unit. Unit seniority shall become effective at the end of the applicable probationary period, but shall date from date of commencement of that period.

**7.4.2. Section Seniority.** The length of service on a regular, full time basis in the applicable line of progression. Section seniority shall begin with the first full day of work performed in the section on a regular, full-time basis. Section seniority shall not apply to those employees in D&D except that employees with section seniority, who are demoted into D&D due to force reduction, shall retain their section seniority for promotional purposes. It is understood that when more than one employee enters a section the same day where section seniority applies, the employee with most unit seniority shall be considered senior. When unit seniority is equal, the Union will inform the Company of the order of seniority.

**7.5. Service Benefit Date.** The date from which length of service is determined for the purpose of computing employee benefits such as personal leave, unavoidable absence benefits, and insurance.

**7.6. Seniority for Temporary Employees.** Employees hired for work of a temporary nature and who are expressly advised of the temporary nature of their employment, shall establish no seniority during such temporary employment. If such an employee accepts a regular full-time job within a recognized bargaining unit covered by this Working Agreement, the employee's unit seniority will begin on the first day he works as a regular full-time employee. The Company will notify the Union of all such employees hired.

**7.7. Seniority and Leaves of Absence**

**7.7.1. Administrative Leave of Absence.** An employee returning to work

from an Administrative Leave of Absence authorized by the Company shall retain the amount of seniority which he accrued prior to going on Administrative Leave.

**7.7.2. Inactive Status.** An employee returning from Inactive Status authorized by the Company will accumulate section (where applicable) and unit seniority up to twelve (12) months while in that status. If at the expiration of his Inactive Status he is granted Administrative Leave of Absence due to continued absence due to injury or illness, he will accumulate unit seniority for an additional eighteen (18) months.

Any employee whose combined Inactive Status and Administrative Leave of Absence periods exceed thirty (30) months shall be allowed to retain all seniority accrued to him at the end of the thirty (30) month period.

**7.7.3. Returning from Layoff.** An employee returning to work on a regular, full time basis from layoff within thirty (30) months from date of layoff will be credited with all applicable seniority as though he had not been laid off, provided he has complied with Subsection 8.3, Reemployment, Article 8. In the event the Company elects to rehire within thirty (30) months from date of layoff, an employee who failed to comply with Subsection 8.3, Reemployment, will be credited with the unit seniority he had at the time of such layoff.

**7.8. Termination of Seniority.** All seniority or length of service under Service Benefit Date immediately terminates in the event of resignation or discharge for cause.

**7.9. Assignment Out of the Bargaining Unit.** In the event an employee is promoted or assigned out of the bargaining unit, the employee shall continue to accumulate length of service and unit seniority for a period of six (6) months. It is understood that transfer back to the bargaining unit within the six (6) month period shall be at the sole discretion of the Company. In the event the employee is not transferred back to the bargaining unit within the six (6) month period, all seniority shall terminate.



**7.10. Seniority Units.** There is only one seniority unit referred to as the Operations and Maintenance Unit. For the purpose of this Agreement, the Operations and Maintenance Unit will include all employees represented under this Collective Bargaining Agreement.

**7.11. Deviation by Mutual Agreement.** Deviations from the above procedures will be made by mutual agreement between the Union and the Company in writing.

**7.12. Vacation Preferences.** Vacations will be bid in conjunction with bids. Vacation preferences will be honored by section/unit seniority of the employees within a classification and work area.

**7.12.1. Vacation Preference Process.** The employee with the most section/unit seniority within each classification in a work area will have first choice of vacation preference. He will not be allowed his second choice until all employees within his classification in the same work area have been allowed a choice in order of section/unit seniority. Each subsequent choice will be made using the same process. A vacation preference choice is considered to be any group of consecutive work days. Vacation requests made after the vacation bidding process will be determined by date of written request but will not be given precedence over the established schedules.

## ARTICLE 8

### PROMOTIONS, DEMOTIONS, TRANSFERS, LAYOFF'S, TERMINATIONS AND REEMPLOYMENT

#### 8.1. Definitions

**8.1.1. Discharge.** Termination for just cause. Discharge creates an unsatisfactory service record.

**8.1.2. Resignation.** An employee's voluntary termination of employment.

**8.1.3. Layoff.** As used herein means termination for reduction in force. An employee laid off retains satisfactory record of performance with the Company.

**8.2. Demotions and Layoff.** Employees may be demoted (a) at their own request; (b) because of documented failure to perform essential job functions; (c) because of reduction in force; or (d) because of failure to certify/qualify or recertify/requalify or to maintain license as required.

**8.2.1. Demotion at Employee's Request.** An employee demoted at his own request shall be demoted in accordance with the applicable line of progression (See Exhibit "B") and shall be required by the Company to remain in the classification to which he was demoted for a period of three (3) months before being eligible for promotion.

**8.2.2. Involuntary Demotion.** An employee demoted by the Company because of documented failure to perform essential job functions or failure to certify/recertify or qualify/requalify or to maintain license shall be demoted in accordance with the applicable line of progression (See Exhibit "B"). Supervision will counsel the employee on the reason for any such demotion. Such employees will be eligible for promotion after a period of two (2) months from the date of demotion and

may be required to pass a written and/or practical test as concurred to by both the Union and Company.

**8.2.3. Transfers or Demotions Due to Reduction in Force.** Transfers or demotions due to a reduction in force within any classification, will be made on the basis of unit seniority or section seniority if it exists, except as outlined in Article 18, Apprenticeship Program. The affected employee shall displace the junior employee working a job that the affected employee is qualified to perform. The employee must be able to satisfactorily perform the job without skill-specific training. The employee will be allowed a reasonable period for familiarization, exclusive of the time necessary to accomplish specific indoctrination requirements.

In the event an employee in the Operations and Maintenance Unit does not have sufficient seniority to displace another employee or does not choose to exercise seniority as provided above, he may regress to the HRT or D&D Helper classification if qualified (the employee will be allowed a reasonable period for familiarization, exclusive of the time necessary to accomplish specific indoctrination requirements) or be laid off and receive severance pay in accordance with Article 13. It should be noted, however, that an employee in Operations and Maintenance electing to be laid off rather than regressing to the D&D Helper classification and returning to the D&D Helper classification or the classification/section from which they were laid off within thirty (30) months from date of layoff shall retain section/unit seniority for promotional purposes within the section/unit from which he was laid off as outlined in Article 7, Subsection 7.4.1. and 7.4.2.

**8.2.3.a. Transfers or Demotions Due to Reduction in Force (Dosimetry).** Transfers or demotions due to a reduction in force within the Dosimetry Technician classification, will be made by the junior/least qualified employee in the line of progression, except as outlined in Article 18, Apprenticeship Program. The affected employee shall regress down the classification and displace the junior employee.

**8.2.4. Displacements.** The Company shall determine on the basis of work

requirements from which classifications layoffs will occur. It is understood that nothing in the Collective Bargaining Agreement shall be construed to mean that any employee shall be placed in a job for which he/she is not qualified. The employee will be allowed a reasonable period for familiarization, exclusive of the time necessary to accomplish specific indoctrination requirements.

**8.2.5. Reclassification Due to Failure to Become Certified.** It is the Company's intent to provide training and run-time for certifying Operator Helpers for promotion to Operator. Operator Helpers who fail to certify for promotion to Operators within twenty-four (24) months from date of entry into the position will be returned to the classification in the unit which the employee was in prior to entry into the Operator Helper classification, or have the option to go to the D&D Helper.

**8.2.6. Reduction in Force Due to Classification Abolishment.** In the event of a reduction in force due to the abolishment of a classification, the affected employee(s) will be afforded rights in accordance with 8.2.3.

**8.2.7.** Should an involuntary lay off be necessary during the term of this agreement, any temporary employee in the classification in which the layoff occurs will be terminated prior to a full time employee in the classification being laid off. The Company will meet with the Union prior to a reduction in force to explain the details including a list of affected employees when available.

**8.3. Re-employment Following Layoff.** For thirty (30) months following layoff, such laid off employees with at least ninety (90) days continuous employment immediately prior to layoff shall be given preference in re-employment. The employee's applicable unit or section seniority will be the determining factors in filling vacancies in the Helper classification, job classification or line of progression the employee held at the time of layoff, provided the employee meets entry level requirements to perform the work. The Company shall not be required to consider any employee for reemployment who does not notify the Manager of Labor Relations, in writing, fifteen (15) days after the layoff and at least every six (6) months thereafter of his desire to be reemployed. The

Company will give such notice of the re-employment offer by certified mail addressed to the employee's last address as shown in the Company's records. A copy of this notice will be sent to the Union. Failure to notify the Company of acceptance within fifteen (15) days of mailing will result in loss of seniority for recall.

**8.3.1.** If a CWI job opening exists which is not filled internally at the DOE Idaho site, and a USW Local 652 bargaining unit member on the USW-BBWI seniority roster in effect January 31, 2005 applies for the opening, and if that person is hired by the Company, their seniority will be recognized by CWI.

**8.4. Terminations.** The Company reserves the right to discharge or suspend any employee for just cause. Such action by the Company is subject to the grievance and arbitration procedures set forth in Article 15, Subsection 15.6.

**8.5. Promoting from Lower Classifications.** When promoting, the practice of the Company will be to promote employees in accordance with the applicable line of progression if any (See Exhibit "B") based upon seniority and qualifications. If there are no employees meeting the requirements for promotion from within the bargaining unit, vacancies may be filled by the Company from any other available source.

**8.6. Upgrades**

**8.6.1. Temporary Upgrades.** Senior qualified and available employees may be temporarily upgraded for absentee relief, vacation relief, or other temporary situations occurring in their respective line of progression/advancement. Employees will receive the applicable upgrade rate for the position they are filling.

These upgrades should last less than one-hundred twenty (120) days. If the upgrade exceeds one-hundred twenty (120) days, the Company will discuss the reasons for the extension and the Union will be provided an opportunity to provide alternatives.

**8.6.2. Lead Upgrade.** If the Company deems it necessary, it may upgrade an employee to act as lead. Employees designated as lead under this provision will not

exceed one-hundred eighty (180) days. If necessary after this assignment, the lead will be offered to other qualified employees within the classification in the area. If there is no interest, the same employee may be assigned to act as lead. The employee upgraded shall be paid an hourly wage rate of \$1.60 per hour above the regular base wage rate or \$1.60 per hour above the base wage rate of the employee in the highest classification (this excludes any red-circled employee or an employee working outside their classification) working in the work group, whichever is higher. Employees will not be forced to take a lead position.

**8.6.2. a. Lead for Support of Supervision.** Employees may be designated to assist supervision as the person in charge of giving management determined work direction assignments to employees in their own specific classifications and/or other crafts on specific jobs. Employees in this capacity may be required to use the tools of their classification.

**8.6.2.b. Lead as Designated Point of Contact for Work Direction.** Employees may be designated as a point of contact reporting to a designated member of management in the area. Employees in this capacity may be required to use the tools of their classification for which they are qualified.

**8.6.3. Upgrade for Non-Represented Position.** If the company deems it necessary, it may upgrade an employee as a planner or technical procedure writer not to exceed one hundred eighty (180) days. If necessary after this assignment, the upgrade will be offered to other qualified employees within the classification in the area. If there is no interest, the same employee may be assigned to the upgrade. It is not intended for this upgrade to apply in cases where participation in work planning or procedure review is incidental to the job. Employees upgraded shall be paid an hourly rate of \$1.25 above their current base wage rate. Performance of non-represented work by represented employees during such upgrades will not cause the work to become represented work. Represented employees covered by this agreement may be upgraded to other non-represented positions when mutually agreed to by the Union and Manager of Labor Relations.

**8.7. Probationary Period Following Promotion or Transfer.** In the event of promotion or transfer to another classification, there will be a probationary period of sixty (60) calendar days. If at any time during said period the employee is determined to be unsatisfactory, he will be notified accordingly and may be returned to his previous classification at any time during the probation period, without loss of seniority. The question of the employee's satisfactory filling of such job shall be subject to the arbitration procedure as provided in this contract.

**8.8. Procedure for Filling Vacancies**

**8.8.1. Posting.** Job vacancies will be posted by the Company.

**8.8.2. Length of Posting.** Job vacancies will be posted for seven (7) working days. Individuals applying for posted openings must submit their interest on the Company approved form to the Internal Staffing Office no later than noon the seventh (7th) day following the end of the posting period.

**8.8.2.a. Bid Procedure.** Qualified individuals with bid rights to posted openings must submit their interest in writing to the Labor Relations Office indicating an interest in a posted job vacancy. The most senior qualified employee who has expressed written interest in the job vacancy will be awarded the job. The successful bidder must remain in the bid position for twelve (12) months.

**8.8.2.b. Reduction in Force Transfers in Non D&D Job Classifications.** If an employee is transferred due to a reduction in force and an opening occurs in his previous area, such employee will be afforded the opportunity to return provided they express their interest by utilizing the bid process for a one (1) year period. If an employee exercises his bid rights to another area during the one year period, he no longer retains his right to return to his previous area.

**8.8.2.c. Transfers.** The transfer of the successful bidder will take place within three (3) weeks after the award.

**8.8.2.d. Area Surplus (After Bidding).** If the Company identifies it has too many personnel in a classification in an area and job vacancies within the same classification exist in another area, those job vacancies will be filled by offering it to the most senior qualified volunteer in the area where the surplus is identified. If there are no qualified volunteers, the low senior employee within the identified area will be forced.

**8.8.3. Vacancies Created by Transfers.** Vacancies created by transfers of successful bidders, as well as lateral transfers, demotions, or subsequent promotions due to reduction in force, will not be subject to bidding.

**8.8.4. Directed Reassignment.** If the Company has identified excess personnel in a classification covered by this working agreement and a full-time regular job vacancy within the Company exists, the vacancy will be offered to the senior qualified volunteer in the classification that has the excess. If there are no qualified volunteers and the low senior employee within the classification is qualified, he will be offered the vacancy. If this employee declines the offer, he will be released from employment. If the offer was not at a wage comparable to the employee's current position, he will receive severance pay in accordance with Article 13. If there is no qualified volunteer and the low senior employee is not qualified, he will be laid off in accordance with Article 8.2.

**8.9. Temporary Assignment Due to Radiation Exposure.** Employees may be temporarily reassigned in accordance with the principles of ALARA. In the event an employee's radiation exposure record becomes such that he cannot be permitted to work in areas of radiation for an extended period of time, and the employee is transferred to a cold area, the vacated job would then be filled on a voluntary basis from among employees in that classification in the area to which the employee is transferred. If no one volunteers, the position will be filled by assigning the employee with the least section



or unit seniority in the classification and area to which the affected employee was transferred. An employee will return to his former area when his radiation exposure record will permit him to be used for regular work assignments in his permanent area.

**8.10. Bidding Procedure Requiring Job Qualifications.** It is understood that nothing in this bidding procedure shall be construed to mean that any employee shall be placed in a job for which he is not qualified.

**8.11. Assigning Shifts.** The Company will assign qualified employees to the available shift or day assignments on an annual or semi-annual time schedule. With respect to the above assignments, the practice will be as follows:

**8.11.1. Preference for Shift or Day Positions.** The available shift or day positions will be filled by preference of those with the greatest seniority in their classification in a work area. Those exercising their seniority for shift or day positions will remain on the assignment until the next shift bid.

**8.11.2. No Preference for Shift or Day Position.** If the shift or day positions cannot be filled by preference, it will be filled by Company assignment starting with the lowest qualified employee on the seniority roster in the work area. Those so forced to such an assignment will remain on the assignment until such time as their seniority permits them to move back to their original assigned day or shift position. If a junior employee in the work area becomes qualified for shift or day work in the interim period such junior employee may be forced on shift work, allowing the most senior employee forced to work the assignment the opportunity to return to their previous assignment.

**8.11.3. Assignment to Crews.** Management will assign successful bidders to the specific crews.

The above shall not be construed to restrict management's rights pursuant to Article 3 of this Agreement. If individual specific needs dictate a change in shift or day

assignments, the Company will advise the Union prior to such changes. Management will consider personal preference in the assignment of employees to specific shift crews on a case by case basis consistent with operational needs. Nothing herein is intended to restrict the Union's rights under the grievance procedure, Article 15.

**8.12. Standardized Written Tests.** The Company in cooperation with the Union will administer standardized written tests, if required, to new hires, recalled employees, and current employees being considered for promotion in connection with the specialist, first and second class maintenance classifications and will give a practical test, if applicable, of a similar nature as given to current employees, to new hires and recalled employees within the first thirty (30) days of employment. Failure by a recalled employee to pass either the written or practical test will not be cause to disqualify him from rehire, but will be used to identify areas where individual training is needed.

**8.13. Temporary Assignments.** The Company may temporarily assign employees from one area and/or classification to another to perform other work for which they are qualified, when deemed necessary by the Company. Temporary assignments beyond 30 days will require mutual agreement between the company and the Union. This provision does not apply to those employees/classifications identified in Article 20.12.a. who are subject to site wide assignment.

**8.13.1. Reporting.** In all cases of temporary assignment, the employee will be responsible for reporting to work at his temporary work area at the scheduled time of his shift.

**8.14. Area Preference Bids.** Annually, Mail Room (Town/Site), and Printing personnel (e.g. INTEC, CFA, RWMC, RTC, TSA) will have the opportunity for area preference bids. The Company will consider the job duties required by the Company and the circumstances of individuals in making these assignments.

**8.15. D&D Positions.** When the Company determines that D&D positions are available, full time employees will have the opportunity to volunteer for D&D assignments by seniority. Employees must be qualified in the classification for which they volunteer. The Company will provide D&D training to qualified volunteers.

**8.16. Ability to Assign/Lease Employees.** In order to provide work for employees for the longest possible time, the Company will be permitted to assign/lease employees to work within their classification to subcontractors at any tier to perform work on site. Employee seniority and benefits will continue to accrue, employees will continue to receive the wage rate of their classification during such assignments, and they shall remain employees of the CH2M-WG Idaho, LLC during such periods.

**8.17. Base Freight Positions.** Base freight positions will be bid on an annual basis. In the event of an opening within the position outside the regular bid process the position will be posted as set forth in Article 8.8.1, 8.8.2, and 8.8.2.a.

## ARTICLE 9

### WAGES CLASSIFICATIONS

#### **9.1. Wages.**

The company offers a 4% general wage increase effective the first pay period following ratification of the agreement retroactive to April 30, 2007. Then a 3% general wage increase effective April 28, 2008, followed by a 3% general wage increase effective April 27, 2009. The Company calculates wage increases using the total average hourly earnings of employees in the Bargaining Unit. This proposal is contingent upon ratification of the entire agreement by the affected membership no later than May 4, 2007.

Red-circled employees will receive a 4% increase in 2007, a 3% increase in 2008 and a 3% increase in 2009 based on their red-circled rate. If any of the percentage increases results in an employee's base rate exceeding either the 2007, 2008 or 2009 rate, that portion of the percentage increase above the 2007/2008/2009 rates will be annualized, based on 2080 hours, and given to the employee as a wage supplement.

**9.2. New Jobs.** Each new job created within the bargaining unit will be given a classification, organization status, and wage rate equitable with those shown on Exhibit "A". The Company shall give the Union advance notice of a classification and shall afford the Union reasonable opportunity to discuss with the Company the rate which should be established. Within thirty (30) days after the establishment of such job rate, if agreement cannot be reached on the job rate, the Union may file a grievance about the rate that the Company has established. Such action on the part of the Union will not preclude the interim filling of the job at the rate established by the Company.

**9.3. Work in a Higher-Paid Classification.** If an employee is temporarily assigned to a job classification having a higher hourly rate than the rate of his regular classification, for other than training purposes, he shall receive the hourly rate of pay of

the job classification to which he is temporarily assigned for the hours actually worked in that classification, or two (2) hours whichever is greater.

**9.4. Work in a Lower-Paid Classification.** If an employee is assigned temporarily by his supervisor to perform work in a lower classification, no reduction in rate shall be made.

**9.5. Rate of Pay upon Promotion.** An employee promoted to a higher job classification shall be paid at the rate of that classification that results in a wage increase beginning with the first full day of that work. The time and grade provision in the wage classification schedule will be applied.

**9.6. Pay Days.** Payment of compensation shall be made at least biweekly.

## ARTICLE 10

### SHIFT DIFFERENTIAL

#### **10.1. Shift Differential Rates.**

**10.1.1. Rotating Shifts and Sliding Twelve Hour Shifts.** Employees assigned to a rotating shift or sliding twelve hour shift on a full-time basis will receive a differential of \$.65 per hour for all hours worked.

**10.1.2. Fixed or Alternating or Shift Relief Workers.** Employees assigned to a fixed or alternating shift on a full-time basis or shift relief workers will receive a shift differential of \$.75 per hour for all hours worked on the evening shift (4 p.m. to 12 midnight) and a shift differential of \$1.00 per hour for all hours worked on the night shift (12 midnight to 8 a.m.).

**10.1.3. Shift Workers on Overtime.** Overtime rates will be computed at one and one-half (1 1/2) times the sum of the regular base rate and any applicable differential.

**10.2. Day Workers.** Regular day workers who are required to work overtime or perform call-in work shall not be entitled to shift differential.

**10.3. Restricted Application of Shift Differential.** Shift differential will apply only to hours worked. For example: Shift differential will not be paid during vacations, holidays not worked, or other absences from work.

## ARTICLE 11

### HOLIDAYS

#### 11.1. Holidays.

**11.1.1. Schedule.** Employees will be eligible for eighty (80) hours of holiday per year observed under the Company's annual holiday schedule.

**11.1.2. Holiday Pay Reconciliation.** Employees will have a holiday pay reconciliation at the end of each calendar year to ensure they are paid no more or less than 80 hours prorated on the basis of the number of holidays for which they were entitled.

**11.2. Pay for Holidays.** Employees will receive straight time pay for all their scheduled holiday hours whether worked or not. Employees will also receive time and one-half (1 1/2) for all hours worked on a holiday, including applicable shift differential.

**11.2.1.** An employee whose last scheduled workday on a forty-eight (48) hour work week falls on a holiday will be permitted to code all overtime hours in excess of forty (40), that are actually worked on the holiday, on the last scheduled work day prior to the holiday.

**11.3. Holiday Pay Restrictions.** Pay under Sections 11.2 above is not applicable to those employees on leaves of absence, inactive status, and unapproved absence. An employee who is off work in another paid leave status shall receive his daily straight time base pay for the appropriate holiday hour schedule in lieu of any other paid leave benefits.

**11.4. Pyramiding of Holiday Premium.** There will be no pyramiding of holiday premium and overtime premium for hours worked on a recognized holiday. All overtime hours worked by an employee on a recognized holiday will be paid at the standard holiday premium rate of one and one-half (1 1/2) times.

**11.5. Holiday Curtailment.** The Company may have a holiday curtailment during the Christmas/New Year time period, which will be mandatory for all non-essential workers. During the holiday curtailment, employees not required to work will need to record either personal leave or "0" time (unpaid leave) to cover any hours above the yearly allotted eighty (80) hours.

**11.6.** A day worker may annually elect to observe Veterans Day on November 11 as a holiday in lieu of the last designated holiday in December, providing the election to observe Veterans Day is made at the time of the vacation preference process. Any day worker so making the election will be required to record either personal leave or "0" time to cover that December day.

In addition, the parties agree to abide by the Holiday schedule as published by Human Resources.



## ARTICLE 12

### PREMIUM PAY

**12.1. Call-Out Pay.** Whenever an employee is called out to work outside his regular schedule, the employee shall receive a minimum of four (4) hours pay at the Site or two (2) hours pay for town at one and one-half (1 1/2) times. It is understood that this provision does not apply in cases where the employee is held over beyond his scheduled quitting time, or where he is called in and works through to his scheduled starting time. When an employee is called out to work regularly scheduled hours on a holiday after having been advised he would not be required to work such scheduled holiday hours, the employee shall receive pay for the actual hours worked as provided for in Article 11. Such call-outs shall not be construed as schedule changes.

**12.1.1. Transportation.** When transportation is not available, and an employee is authorized by the Company to drive a privately-owned vehicle, the employee shall receive the mileage rate allowed employees of the Company by DOE for the miles necessary to travel from home to work and back home. The Company shall not require an employee to transport other employees in his privately-owned vehicle.

**12.2. Reporting Pay.** Whenever an employee reports for work at his regular starting time, without previously having been told not to report, he shall be guaranteed four (4) hours work. If the Company should fail to provide the expected four (4) hours work, then the employee shall be paid for four (4) hours at his regular base rate.

**12.3. Reactor Certification/Qualification Differential (TRA Area).**

**12.3.1. Maintenance Employees.** Employee assigned to work at ATR and required to qualify and maintain qualification as reactor maintenance support personnel as defined in the TRA Training Program Manual will receive seventy-five (\$.75) cents per hour qualification differential (except red-circled employees).

**12.3.2. TRA Senior Reactor Auxiliary Operator (SRAO).** SRAOs assigned on a regular full-time basis work at ATR will be required to certify and maintain certification as defined in the TRA Training Program Manual, ATR certification/recertification program schedule. SRAOs who qualify will receive a certification differential of \$1.30 per hour.

**12.3.2.a. Lead Senior Reactor Auxiliary Operator (LSRAO).** SRAOs who qualify initially as LSRAO will receive forty-five (\$.45) cents certification differential. SRAOs standing watch as LSRAO will receive an additional thirty-six (\$.36) cents plus the current rate of lead upgrade.

**12.3.3. Applicability of Differentials.** The above qualification or certification differentials as applied to ATR Maintenance or Operations will be paid for regular straight time and overtime hours and paid holidays and personal leave hours. The differentials (except those in Article 12.3.2.a.) will not be included in the computation of retirement or investment plan benefits however.

**12.3.4. Forfeiture of Differentials.** Operations or Maintenance employees that fail to recertify or requalify in accordance with the TRA Training Program Manual will forfeit all further certification/qualification differentials until they successfully recertify or requalify.

**12.4.** If an employee is scheduled to work overtime before the end of his last scheduled shift in the preceding week, or if the employee is offered overtime with twenty-four (24) hours notice, no Company transportation costs (i.e. mileage, money or government vehicle) will be provided.

If an employee is assigned on a previous work day to work overtime beyond their regularly scheduled shift and the Company fails to notify the employee that the overtime has been cancelled with less than twelve (12) hours prior notice of such cancellation, the employee will be worked/paid (as determined by the Company) at least two (2) hours at the applicable rate.

**12.4.1** If management requests or approves of an employee providing a ride home to another employee following overtime work the employee will be paid one (1) hour at the applicable rate (government or private vehicle).

## **ARTICLE 13**

### **SECURITY PLANS BENEFITS**

Qualified employees are eligible to participate in the following INL benefit programs:

Personal Leave

Medical Plan

Dental Insurance Plan

Vision Insurance Plan

Health Care Flexible Spending Account

Dependent Day Care Flexible Spending Account

Employee Life Insurance

Spouse Life Insurance

Dependent Children Life Insurance

Accidental Death and Dismemberment Insurance

Short Term Disability Insurance

Long Term Disability Insurance

Workers Compensation

Long Term Care Insurance

Service Awards

Leaves of Absence

Retirement Plan

Investment Plan

Holidays

Severance Pay

All security plans and benefits arranged by the Company for its employees, as a whole, will be available to employees covered by this Agreement and will be administered equally, including that portion of the cost paid by all employees.

The Union will be informed in advance of any additions or substantive changes to, or deletions from, the benefit programs.

## ARTICLE 14

### LEAVES OF ABSENCE FOR UNION BUSINESS

**14.1. Leave of Absence for Employment by Union.** Any member of the Union shall be granted leave of two (2) years or less from his employment with the Company for the purpose of accepting employment with the Union. The request for leave shall be in writing and shall state the purpose for which it is made and that the employee intends to apply for reinstatement to his job. Application for reinstatement, if made thirty (30) days or more prior to the end of the leave period, will be considered and accepted on the following conditions:

**14.1.1. Physical Condition.** His physical condition continues to permit him to perform the essential job functions of his prior job. Physical examinations shall be made by the Medical Division of the Company immediately prior to leave and upon reinstatement. In the event of a dispute as to the employee's ability to perform essential functions of his prior job, such dispute may be resolved at the discretion of the employee or the Company in accordance with the provisions of Article 20, Subsection 20.4.

**14.1.2. Security Requirements.** Prior to reinstatement, the employee shall meet the applicable security requirements.

**14.1.3. Seniority Retention.** The employee, upon reinstatement, will reenter his former classification and will be accorded the same seniority as though he had not gone on leave.

**14.1.4. Benefits.** With respect to benefits, such employee shall be accorded the same rights and privileges as are provided an Administrative Leave absentee.

**14.1.5. Limits on Number of Employees on Leave.** This Subsection shall not be applicable to more than three (3) employees at any one time but no more than one (1) from any area or classification unless mutually agreed upon. When any three (3) members of the Union are on such leave, the terms of the Section shall be suspended as to all other members.

**14.2. Leave of Absence to Conduct Union Business.** If plant conditions permit, leaves of absence aggregating not more than one hundred fifty (150) calendar days, excluding the Local Union President's time, per calendar year will be granted during the period of this Agreement, provided that not more than five (5) employees shall be granted simultaneous leaves and that not more than one (1) employee from each area shall be granted simultaneous leaves. Where circumstances occur and plant conditions permit, management will consider simultaneously releasing more than the number of employees specified above, or extending the limit on aggregate calendar days.

**14.2.1. Requests for Leave.** All requests for such leave will be given to Labor Relations in writing as early as possible during the week prior to the week in which the leave is requested. This written request will indicate the date(s) the employee(s) desire to leave and return. Such leaves of absences shall be without pay, but shall not affect the status of employees with respect to service benefits or seniority.

## ARTICLE 15

### GRIEVANCE PROCEDURE

**15. Grievance Process.** Any grievance and/or difference of opinion which involves application or interpretation of the terms of this Agreement or any other matter respecting conditions of employment shall be handled in the following manner:

**15.1. Step 1.** The employee and/or Union representative shall present the complaint either verbally or in writing to the employee's immediate supervisor within ten (10) days of knowledge of occurrence of the grievance and advise the supervisor that such complaint is being filed as a grievance under Step 1 of this Article, except that grievances involving discharge or disciplinary suspension will be filed according to the provision outlined under Subsection 15.6. of this Article.

**15.2. Step 2.** The supervisor shall render his decision within five (5) working days after presentation.

**15.3. Step 3.** Failing to reach a satisfactory understanding or adjustment with the supervisor, the grievance may be presented in writing within eight (8) days of the supervisor's decision to the next level of supervision. The employee and/or Union representative and that supervisor will date and sign such written grievance documenting that a discussion has occurred and forward the written grievance to Labor Relations. This step can be bypassed if supervisory signature can not be obtained.

**15.4. Step 4.** The grievance shall be considered at the next monthly meeting with the Workmen's Committee. However, a special meeting may be called by mutual agreement at any time. If the grievance is presented by the Union, and a satisfactory understanding or adjustment is not reached in the Workman's Committee meeting, the Manager of Labor Relations or the designee, shall render to the Union the Company's decision in writing within eight (8) days.

**15.5. Arbitration.** If the decision of the Manager of Labor Relations is not satisfactory and if the dispute involves the application or interpretation of this Agreement, such dispute may be submitted to arbitration. If the Union desires to submit such dispute to arbitration, it will so notify the Manager of Labor Relations in writing within twenty (20) days from the date of the decision. Together with such notice or at any time subsequent prior to the arbitration, the Union or Company may request that a pre-arbitration meeting be held at a mutually agreeable time and place in an attempt to resolve the dispute. Neither party shall unreasonably refuse such a request. Attendance at the pre-arbitration meeting shall normally be limited to three persons each from the Union and the Company. If the dispute is submitted to arbitration, the parties shall, within five (5) days, join in a request to the Federal Mediation and Conciliation Service to submit the names of five (5) arbitrators available for convening a hearing in sixty (60) calendar days. Upon refusal of either party to join in such a request, the other may make the request. The parties shall meet within ten (10) days to select an arbitrator (if the list received does not contain arbitrators willing to hear the case within sixty (60) calendar days the parties may request an additional arbitrators list). The Union and the Company shall alternately strike a name from the list (the first to strike shall be determined by lot) until the name of one individual remains. The remaining individual shall be the sole arbitrator of the question involved. Upon refusal of either party to strike names, the Federal Mediation and Conciliation Service may, upon request of the other party, appoint an arbitrator. The arbitrator's decision shall be final and binding on both parties. The parties will jointly request the arbitrator to render a decision within sixty (60) calendar days after close of hearing. The arbitrator shall not have the power to add to, disregard, or modify any of the terms of this Agreement. The fees and expenses of the arbitrator shall be borne equally by the Union and the Company. If either party requests a court reporter, the court reporter's record will be the official record of the proceedings. The requesting party will pay the cost of the court reporter, and should the other party desire a copy of the proceedings, they should request and pay for same from the reporter. Upon mutual agreement of the Company and the Union, videotaping of the proceedings may be allowed. Not more than one (1) case at a time may be submitted to an arbitrator except by mutual agreement. Arbitration cases will be heard in order of appeal. The parties may



agree to expedite discharge/termination cases and cases involving laid off workers. Notwithstanding Section 15.8 herein, cases appealed to arbitration will be heard by an arbitrator within one hundred and eighty (180) days after receipt of an acceptable panel.

**15.6. Discharge or Disciplinary Suspension.** In the event of discharge or disciplinary suspension, if the individual concerned believes he has been discharged or suspended without just cause, the Union or the employee may present the matter in writing to the Manager of Labor Relations within five (5) days from the time of such discharge or disciplinary suspension and not thereafter. At the time of such disciplinary action, the Union President or Vice President will be notified.

Within eight (8) days after such matter is presented to the Manager of Labor Relations, he or his designated alternate will render a decision in writing. If the parties remain in disagreement at the conclusion of the foregoing steps, such complaint may be presented through the regular arbitration procedure starting with Subsection 15.5 of this Article.

**15.7. Communicating to the Company.** Subject to the procedure set out above, nothing in this Article shall prevent any employee from individually presenting complaints, suggestions, questions, or requests to the Company.

**15.8. Lapsed Time.** Lapsed time references in this Article are calendar days, excluding Fridays, Saturdays, Sundays, or holidays. The date of occurrence shall not be counted and days start at 12:01 a.m.

**15.9. Waiver of Time Limits.** Mutual agreement of the Company and the Union on, waiver of time limits on a case-by-case basis does not constitute a precedent or permanent waiver of time limits.

## ARTICLE 16

### UNION COMMITTEE EMPLOYEE REPRESENTATION

**16.1. Area Representatives.** Area Representatives, Unit Representatives and Stewards shall be selected from among the employees in the bargaining units in accordance with Local 652 Constitutional By-Laws. The Union will furnish to the Company a current list in writing of representatives as changes occur.

**16.2. Committees.**

**16.2.1. Area Workmen's Committees.** Workmen's Committees normally made up of four (4) members each from the Union and the Company will be established in INTEC, RWMC, TAN and in other areas by mutual agreement. The meetings will be co-chaired by a Union representative and a representative from Labor Relations. Committee composition will be mutually agreed to before each meeting by the co-chairman. As a general guide, the meetings will be attended by the area representatives and unit representatives having business at the meeting. The committee will meet monthly at mutually agreed upon times and places unless waived by both parties. The purpose of these meetings shall be resolution of individual or mutual problems/questions and grievances arising under this Agreement pertaining to the specific area the committee represents. Committeemen shall not lose pay for time scheduled to have been worked by reason of attending these meetings.

**16.2.2. General Workmen's Committee.** A General Workmen's Committee shall be established. The committee shall consist of up to six (6) area representatives and be co-chaired by the Union President and the Manager of Labor Relations or the designee. The committee will meet at mutually agreed upon times and places for the purpose of discussing contractual problems/questions, policy-level grievances, and grievances pending arbitration. At the request of either party, appropriate management representatives will attend these meetings. Committeemen shall not lose

pay for time scheduled to have been worked by reason of attending these meetings.

**16.2.3. Labor Management Committee.** Upon mutual agreement, a Labor Management Committee may be established in each area to discuss and resolve non-contractual issues and concerns. The committee will consist of senior management, Labor Relations, and Union representatives from the respective areas. The committee will be co-chaired by a senior management representative from the area and the Union representative responsible for that area. At the request of either party, appropriate management representatives will attend these meetings. Committeemen shall not lose pay for time scheduled to have been worked by reason of attending these meetings.

**16.2.4. Contract Negotiating Committee.** A Bargaining Committee consisting of the local President and up to ten (10) representatives shall be established to conduct negotiations with the Company. The Company will pay the difference between time actually spent in negotiations and the regular straight time wages that coincide with the employees' work schedules and are exclusive of scheduled days off up to a total of ten (10) hours per day or forty (40) hours per week excluding mutually agreed upon breaks.

**16.3. Time Provided for Union Representatives to Confer on Matters of Employee Relations.** Union representatives and other employees, with approval of the Company, may be permitted to confer during the employee's working hours with Company representatives on matters relating to employer-employee relations without loss of pay for time scheduled to have been worked.

**16.4. Time Provided to Handle Grievances.** Stewards or members of the Area Workmen's Committees may leave their jobs without loss of pay for the purpose of assisting in the handling of grievances in their area upon approval of their supervisor. It is further agreed that the supervisor shall not withhold permission where working conditions permit and that only those stewards or members of the Workmen's Committee with direct involvement shall participate.

**16.5. Guidelines for Ad Hoc Committees.** The parties agree to the following guidelines:

1. Represented employees selected to be on the committee shall be agreed upon by both the Company and the Union. Agreement by either party will not be unreasonably denied.
2. Represented employees on the committee shall have the same membership privileges and responsibilities as all other members.
3. If the Company and the Union mutually agree to a co-chair arrangement, both the Company and the Union representative will have equal authority as chairpersons.
4. Clear guidelines shall be established and agreed upon for the committee's activities. These should include a mission statement and key goals and/or milestones.

These guidelines are not intended to restrict shop or specific work area groups from developing recommended solutions to issues arising in the workplace.

## **ARTICLE 17**

### **BULLETIN BOARDS**

The Company will continue to provide locked bulletin boards in conspicuous places. It is agreed that no posted material will reflect against or discredit the Company or any individual employee.

## ARTICLE 18

### APPRENTICESHIP PROGRAM

**18.1. Apprenticeship Program Established.** The Apprenticeship shall be a part of this Working Agreement.

**18.2. Apprenticeship Program Defined.** An employee in the Apprenticeship Program shall be considered to be a member of his respective unit and shall accumulate unit seniority from their date of hire. During the first twenty-four (24) months of an employee's apprenticeship, he shall not be affected by layoffs affecting journeymen classifications except at management's discretion. When an employee's time in his apprenticeship exceeds twenty-four (24) months, he will be affected by a reduction in force within their craft line if such reduction would cause the ratio of one (1) apprentice for each five (5) journeymen remaining in a craft line to be exceeded. (Let it be noted that any time given for prior experience shall be deducted from the apprentice's protection period as described above). If an apprentice is reduced from the Apprenticeship Program under this latter circumstance, then such affected apprentice shall be reduced to his former classification or be laid off based upon his unit seniority.

**18.3. Apprentice Progression Testing and Seniority.** An apprentice shall begin accruing section seniority on the first day of his apprenticeship. Any apprentice that fails to pass one (1) of the six (6) month progression tests or the final test will lose six (6) months of section seniority. Failure to pass either a second (2<sup>nd</sup>) six (6) month progression test or the final test for a second (2<sup>nd</sup>) time will result in immediate termination of his apprenticeship. Only one (1) six (6) month extension will be permitted throughout the term of his apprenticeship. Because of the unique nature of operations and apprentice's requirements to qualify and/or certify on their particular processes, specific guidelines regarding their progression testing and related penalties will be established by the Joint Apprenticeship and Training Committee (JATC). It is understood that time spent on layoff and/or regression shall be credited toward the

original term of apprenticeship as may be deemed appropriate by the Joint Apprenticeship and Training Committee (JATC). Upon successful completion of the apprenticeship program by an apprentice, he/she will be placed on the seniority roster as a journeyman in his/her respective classification.

**18.4. Apprentice Compliance with Working Agreement.** Apprentices will be subject to the provisions of this Working Agreement as apply to employees in their respective units except that any actions of the Apprenticeship Committee that may affect the apprentice shall not be subject to the provisions of Article 15, Grievance Procedure.

**18.5. Preferential Consideration for Union Represented Applications.** Current Union represented regular employees shall be given first consideration for apprenticeship openings within the classifications covered by this Agreement provided that applicants meet the minimum requirements of the apprenticeship program.

**18.6. Apprenticeship Oversight.** Participation and oversight in craft apprenticeship programs will be provided and supported by the craft support department. The Utilities Department will control and provide oversight over the utilities apprenticeship programs. Additional support and oversight will be provided for the total administration of the apprenticeship program, including placement of apprentices.

## ARTICLE 19

### HEALTH AND SAFETY

**19.1. Importance of Health and Safety in the Work Place.** The Company and the Union recognize the importance of maintaining a safe working environment, providing applicable health and safety training, promoting occupational health and accident prevention, and the general elimination of hazards to health and safety in the work place. Recognizing that safety is a joint responsibility, both parties acknowledge the Union Health and Safety Representative and commit to comply with the provisions of 10 CFR 851 and ISMS programs. Both parties will encourage employee involvement in the INL VPP Worker's Bill of Rights and VPP programs on official time.

**19.2. Company Compliance.** The Company will continue to make provisions for the health and safety of employees while at work and agrees to comply with applicable federal laws and DOE rules and regulations pertaining to the health and safety of employees covered by this Agreement.

**19.3. Employee Compliance.** All employees shall cooperate by following safe work practices and complying with health and safety rules during employment, the proven violation of which shall be cause for disciplinary action. Conversely, nothing in this Health and Safety Article is intended to take away the right of the employee to process complaints through the grievance procedure as provided for in Article 15.

**19.4. Union Safety Representation.** There will be an area employee safety team established in each specific area to serve as a forum to provide input for an effective accident prevention program, to discuss effective solutions to safety problems, to recommend corrective measures to eliminate hazards, and to review significant operating occurrences and other accident and injury reports. As required, each team's scope may include on-site inspections. The team will select the chair and Health and Safety will be



represented. The Union will appoint no less than two (2) team members or one (1) team member for each ninety (90) represented employees in the specific area to serve on the area team. The team will meet monthly.

A Union representative of the area safety team shall accompany the safety director or his authorized personnel during the physical inspection(s) of the workplace for the purpose of aiding in the inspection. Such representative will receive results of the inspections.

CWI agrees to fund one full time Health and Safety Representative from the USW work force. The representative will be selected by the local Union President and approved by the CWI Safety Manager. Either party may request the removal of the designated employee with thirty (30) days notice.

The company and Union committee will discuss the use of USW worker/trainers to provide HAZWOPER training.

**19.4.1. Time Allowed for Safety Meetings.** No Union representatives from within the Company shall lose time or pay from their respective work schedule by reason of attending a meeting provided for under this Article.

**19.4.2. Safety Meeting Minutes.** Joint minutes will be recorded of all such meetings and copies distributed to both Union and management representatives.

**19.4.3. Union Participation at Major Accident Investigations.** A Union representative may participate, up to report submittal, on major (Type A or B) accident investigations conducted by the Company which affect a Union member. The representative shall receive all reports covering the investigation.

**19.4.4. Step Back and Stop Work Authority.** Employees have a right and responsibility to decline to perform an assigned task or stop work without fear of reprisal in accordance with the D.O.E. approved Worker Safety and Health program.

## ARTICLE 20

### MISCELLANEOUS

**20.1. Discrimination.** There shall be no discrimination between employees within these bargaining units with respect to any conditions of employment because of membership or non membership in the Union or because of age, race, creed, religion, national origin, gender, veteran status, or disability. References in the working agreement to he, him, and his include the female gender and are not references to gender.

**20.1.1. Compliance with the Americans with Disabilities Act.** The parties acknowledge that they are subject to and intend to abide by the requirements of the Americans with Disabilities Act (ADA). The Union and the Company specifically acknowledge that reasonable accommodations, as defined by the ADA, may include but are not limited to part-time or modified work schedules. Time required by such an individual for physical therapy, rehabilitation, extended rest periods and the like shall not be compensable time unless covered under Article 13.

**20.2. Union and Anti-Union Activity.** Except as allowed by this Agreement, Union or anti-Union activities during work time will not be permitted nor shall such activities be permitted that interfere with work performance.

**20.3. Strikes and Lockouts.** There will be no sympathy strike, work stoppage, slowdown or sit-down by the employees covered under this Agreement or lockouts by the Company during the term of this Agreement. If any such action is taken by an employee or employees covered by this Agreement, the Union shall exercise its responsibility to end such action.

**20.4. Physical Examinations for Determining Fitness for Duty.** The INL Occupational Medical Program (OMP) industrial physicians are responsible for performance of medical evaluations on Company employees to determine their ability to perform assigned tasks and identify work restrictions in accordance with DOE orders. If,

after consultation between the INL OMP industrial physician and an employee's personal physician and/or a recognized physician specialist as applicable, there exists a dispute between the Union and the Company as to the physical fitness of an employee to return to work or to continue to work at his regular job assignment, a board of three (3) accredited doctors of medicine shall be selected: one (1) will be an INL OMP industrial physician, one (1) selected by the Union, and one (1) by the two (2) so-named physicians. The decision of the majority of this board shall be final. In the event the INL OMP industrial physician and the physician selected by the Union cannot reach consensus within ten (10) days in the selection of the third (3rd) physician, the matter shall be referred to the Idaho State Industrial Commission, who shall appoint a third (3rd) Doctor of Medicine in a specialty related to the employee's impairment. Opinions and decisions of a majority of the three (3) doctors shall be final and binding. The Company shall bear the expense of the INL OMP industrial physician and one-half (1/2) of the expense of the third (3rd) Doctor of Medicine. The Union shall bear the expense of the Doctor of Medicine of the Union's choice and one-half (1/2) of the expense of the third (3rd) Doctor of Medicine. The Company and the Union shall also share equally the cost for any additional tests and/or evaluations beyond any insurance covered costs the board of doctors unanimously agrees are necessary to support its charter.

**20.4.1. Confidentiality.** The confidential character of all employee medical records, including the results of health examinations, shall be rigidly observed by all members of the Occupational Medical Program staff. Such records shall remain in the exclusive custody or control of the Occupational Medical Department. Disclosure of information from an employee's health records shall not be made without his or her consent, except as permitted by law.

**20.5. Warning Notices or Employee Ratings.** Any unsatisfactory report or rating which is to be filed as a matter of record shall be filed within thirty (30) calendar days of knowledge of the occurrence and shall be brought to the attention of the employee within said period excluding days the employee is off work on approved leave. The employee shall be given two (2) copies of such notice. The employee shall sign such notice

indicating that the matter was brought to his attention but his signature does not imply concurrence. If an employee requests Union representation during matters discussed under this subsection, the steward or designated alternate will be in attendance. Bargaining unit personnel will be treated consistently with other Company employees under management procedure(s) governing disciplinary action. Warning notices (AVO's) and Employee Performance Notices (EPN's) will, as a matter of record, be kept in the official personnel file maintained by Human Resources.

**20.5.1. Removal of Warning Notices.** Warning notices (AVO's) are documented verbal reprimands and shall remain in an employee's file for at least twelve (12) months. After twelve (12) months the employee may request the warning notice be removed from his file. If there has been no further disciplinary action, the notice will be removed.

**20.5.2. Removal of Employee Performance Notices.** Employee Performance Notices (EPN's) are second step documented reprimands or documented disciplinary action for more serious employee deficiencies. Such notices shall warn employees that further reoccurrence may result in further disciplinary action, including dismissal, and will remain in an employee's file for at least eighteen (18) months. After eighteen (18) months, the employee may request the notice be removed from his file. If there has been no further disciplinary action, the notice can be removed with the concurrence of the employee's supervisor and the Manager of Labor Relations, but will not remain in the file beyond two years unless further disciplinary action has been noted.

**20.5.3. Letter of Rebuttal.** If an employee or the Union disagrees with any step of the disciplinary process (i.e. warning, AVO, or EPN) they may submit a letter of rebuttal in lieu of a grievance to be attached to the disciplinary letter and placed in the same file. If progressive discipline action continues the information contained therein will be used in conjunction with a grievance filed in accordance with Article 15, Section 6. The letter of rebuttal will be removed at the time the disciplinary letter is removed.

**20.6. Bus Transportation Delay.** Bus Transportation to the Site is not a guaranteed service. However, no employee shall lose scheduled time or pay, (including shift differential) because of bus transportation delay. Other transportation delays shall be considered on an individual basis.

**20.7. Standing of this Agreement.** This Agreement contains all subject matter and stipulations agreed upon between the parties and no amendments or modifications to this Agreement can be made except when mutually agreed upon in writing by both parties.

The parties agree that all known MOU's and MOA's have been discussed during the negotiations and the parties have agreed to incorporate many of them into the agreement, to eliminate obsolete ones, and to create contract language to handle specific situations. Therefore, effective with the agreement dated April 30, 2007 only those MOU's and MOA's continued in effect by mutual agreement will be considered applicable. All other MOU's and MOA's not agreed to be continued are null and void.

Although the Company does not agree to include the MOA ICDF Project Subcontracting dated, May 6, 2003, the Union expressly retains their position that the MOA's were in effect at the time the dispute arose regarding the ICDF Project, further the Union is not relinquishing or waiving any of its rights concerning those memos in any pending matter.

However, for the purpose of establishing a legacy record, the parties will retain the agreements on file and in the event that DOL rules the ICDF work as non-covered, and DOE awards the work to CWI, then USW and CWI would bargain the work identified as non-covered.

**20.8. Training Opportunities.** The Company will provide equal opportunity for all employees of comparable standing within a given classification to learn duties and responsibilities of the next job for which they are to become qualified. All employees will, insofar as practicable, provide on-the-job training and assist lower classified and/or

less experienced employees in acquiring job knowledge.

## **20.9.**

**20.9.a. Non-Represented Employees Doing Work.** The Company agrees that there shall be no erosion of the bargaining units by the assignment of tasks performed by bargaining unit employees to non-bargaining unit employees. Non-represented employees will not perform work on any bargaining unit job except where such work is considered minor maintenance or adjustments. Examples of such tasks include changing indicator bulbs and changing ink and pens on recorders. The minor maintenance or adjustments are not intended to infringe upon the jurisdiction of the Union, but are needed in order to operate the facilities economically to the betterment of both parties. It is not the intent of the Company to use non-bargaining unit employees to perform major tasks performed by members of the bargaining unit.

Exceptions to this are as follows: (1) in emergency situations (unforeseen circumstances which require immediate action); (2) in the instruction of employees to perform their responsibilities under normal and/or emergency situations; (3) in training of supervisors and instructors on equipment or processes to allow them to maintain qualifications; (4) in new or specialized work which requires special techniques and knowledge and bargaining unit employees are not qualified; (5) in the performance of necessary work when production difficulties are encountered on the job. (Production difficulties mean those difficulties requiring supervisor assistance. In these cases, bargaining unit employees assigned to the equipment or process will be present while the work is performed); (6) to allow properly qualified planners or facility inspection personnel access to equipment for the purpose of identifying and planning maintenance work (access shall be in accordance with all applicable safety procedures and be limited to removal of access inspection covers for visual inspection only without touching or manipulating internal components); (7) to provide short periods (less than thirty [30] minutes) of relief when no represented employees are available, and (8) to provide assistance to represented Dosimetry employees during loading and unloading of TLD's before and after badge exchange.

In the event of disputes concerning such work assignments, the Company will meet with Union representatives to discuss and resolve such disputes.

**20.9.b. Contracting Out.** The Company shall have the right to contract out work with outside contractors or subcontractors.

When work that would normally be performed by USW represented employees is to be contracted out, the Company will notify the Union. The Union may request a meeting to discuss the details of the subcontract and to suggest alternatives. The parties will set up a mutually agreed upon procedure as to how subcontracting issues will be discussed by the committee with the goal to minimize inefficient subcontracting. The subcontracting committee will be composed of equal numbers of members selected from management and members selected from the Union.

In exercising its right to contract out the Company will observe the collective bargaining agreement provisions.

CWI shall not subcontract or otherwise transfer in whole or in part any work covered by this agreement to be done at the Idaho site, when such subcontracting is for the sole purpose of laying off bargaining unit employees.

## **20.10. Special Provisions**

**20.10.1. Clothing and Small Tools.** The Company will continue to furnish tools, equipment, clothing and other protective/safety apparel and devices as necessary. Where personal clothing of such employee is destroyed (while performing his duties) by acids, caustics, or chemicals under circumstances where the employee was not negligent in failing to use protective clothing, full monetary compensation will be made for such clothing. Each employee will be required to exercise due diligence and account for all tools and equipment issued to him, and for failure to do so may be charged with the value



thereof. If an employee's personal clothing becomes contaminated with radioactive matter to an unsafe degree, the employee's will surrender his contaminated clothing. The employee's contaminated clothing will be returned to the employee when and if it becomes safe again and the employee will then, upon the Company's request, return the clothing which he previously received from the Company. If after confiscation of an employee's personal clothing it is deemed unsafe ever to return them, full replacement compensation will be made to the employee. Coveralls will be provided upon request where it is reasonable and practical in the opinion of the Company.

**20.10.2. Cafeteria Meals.** A meal shall be furnished for each employee assigned to work in the cafeteria for the shift which he works.

**20.11. Bargaining Unit Work in a Pilot Plant Environment.** It is the intent of the Company to use bargaining unit personnel in experimental and developmental activities such as take place in the pilot plant and in experimental laboratories to the extent the Company deems practical. It is recognized that when assigned to such activities, employees may be required to do a variety of duties and supervisors, technicians and professional personnel may from time to time, and in some cases over an extended period of time, perform work of a similar or, in some cases, physically identical nature to those performed by bargaining unit personnel. When a pilot plant makes the transition from purely experimental and developmental to a production plant, it is intended that bargaining unit personnel will perform work for which they are qualified and which historically has been performed by bargaining unit personnel.

**20.12.** Establish Site Wide Assignment Language for classifications and employees effective May 1, 2005.

**20.12.a.** Notwithstanding anything to the contrary in this agreement or in any memorandum, any employee(s) assigned to the classifications listed below may be assigned site wide within their classification at the Company's sole discretion. Such assignment(s) will be without limitation as to time, duration, or work to be performed.

No employee(s) shall be assigned to perform work within their classification without proper training, safety training for the area, core training, and building indoctrination, if necessary.

Such employee(s) seniority standing shall not be determinative in making work assignments across the site within their classification.

The classifications included under this provision are: D&D Helper, D&D Hazardous Reduction Technician, D&D Skilled Trades, Welder, Sheet Metal, Electrician (to include IPO), Instrument Technician, Spent Nuclear Fuel Operators, RadCon Technician, and in-grade positions attached.

**20.13. Temporary Hire.** The Company may hire employees for work of a temporary nature which shall not exceed one-hundred eighty (180) days in any twelve (12) month period, unless extended by mutual agreement between the Company and the Union. The following applies:

1. Temporary employees shall be paid the wages established by the collective bargaining agreement for the classification they are performing.
2. While employed, temporary employees shall be considered for job openings with the Company in classifications which they worked at CH2M-WG IDAHO, LLC after full-time employees on the recall list and full-time employees with 3161 preference.
3. Temporary employees shall be represented by the Union except that termination of an employee's service shall not be subject to the grievance and arbitration procedure. Temporary employees in the bargaining unit are entitled to participate in CH2M-WG IDAHO, LLC benefit programs in the same manner as all other temporary employees at CH2M-WG IDAHO, LLC.

4. Represented employees who have been laid off, and still have recall rights under 8.3, will have the first opportunity to fill temporary positions as temporary hires provided they are qualified for the temporary positions.
5. Henceforth temporary employees will not be upgraded in their classification or to lead man in an area prior to discussions with the Union.

**20.14. Shift Relief Worker Bid.** Where the need has been recognized by both the Union and the Company, shift relief worker positions will be selected by the bid process.

**20.15.** The Company and the Union agree that the hours coded as time off without pay during the “Christmas Curtailment” will not count toward the one hundred twenty (120) hour time off without pay usage limitation if the employee is not scheduled to work.

## ARTICLE 21

### VALIDITY

**21.1. Contract Subject to DOE Directives.** It is understood and agreed that the Company's operations are subject to certain prevailing authorities, including the Company's Management and Operating Contract with the Department of Energy (Contract DE-AC07-05ID14516), the Orders and Directives of said Department and all valid and applicable State and Federal laws. Therefore, the parties intend that this Agreement will be construed in a manner consistent with the prevailing authority. If any provision of this Agreement is or becomes inconsistent with a prevailing authority, the prevailing authority will prevail. Nevertheless, any such inconsistent provisions of the Agreement shall be separable and the remaining provisions shall remain in full force and effect. The parties shall meet for the purpose of negotiating a mutually satisfactory substitute provision if either party demands such a meeting within thirty (30) days of the identification of an inconsistent provision.

## ARTICLE 22

### TERM OF AGREEMENT

**22.1. Terms.** This Agreement shall become effective 12:01 a.m., April 30, 2007, and shall remain in effect through 12:00 midnight, May 2, 2010, and shall continue in effect thereafter unless and until either party shall give at least sixty (60) days, but not more than ninety (90) days prior notice, in writing of its desire to terminate or amend this Agreement. Such term shall not in any case extend beyond the term of the company contract with the Department of Energy (Contract DE-AC07-05ID14516) as may be terminated, modified or extended.

IN WITNESS WHEREOF, the parties have caused this instrument to be executed by their duly authorized representatives this \_\_\_\_\_ day of \_\_\_\_\_.

FOR THE UNION

United Steel, Paper and Forestry, Rubber Manufacturing, Energy, Allied Industrial and Service Workers International Union (USW) on behalf of Local Union 652

Leo W. Gerard  
Leo W. Gerard, International President

James D. English  
James D. English, International Secretary-Treasurer

Thomas M. Conway  
Thomas M. Conway, International Vice President Administration

Fredrick D. Redmond  
Fredrick D. Redmond, International Vice President Human Affairs

Terry Bonds  
District 12 Director, Terry Bonds

Manny Armenta  
Sub-District Director, Manny Armenta

Julie Holzer  
Staff Representative, Julie Holzer

LU Negotiating Committee

Alan G. Wood  
Alan G. Wood, President

Henry G. Littleford  
Henry G. Littleford, Vice President

Roger R. Bennett  
Roger R. Bennett, RTC Area Rep.

FOR THE COMPANY

CH2M-WG IDAHO, LLC

Robert C. Iotti  
Robert C. Iotti, CWI President

Ronald J. Slottke  
Ronald J. Slottke, Vice President of Administration

Robert C. Easdon  
Robert C. Easdon, Corporate Labor Relations

Carl N. Morris  
Carl N. Morris, Director Labor Relations

Bruce R. Gregory  
Bruce R. Gregory, Manager Labor Relations

Kathy A. Morgan  
Kathy A. Morgan, Labor Relations

Brett T. Hobbs  
Brett T. Hobbs, Labor Relations

Dave Armstrong  
Dave Armstrong, Labor Relations

Lee E. Barton  
Lee E. Barton, INTEC HLW Rep.

Bradley P. Clawson  
Bradley P. Clawson, SNF Rep.

LeeAnn M. Eliasson  
LeeAnn M. Eliasson, TAN Area Rep.

Lloyd D. Brittain  
Lloyd D. Brittain, INTEC Maint. Rep.

Gary L. Landon  
Gary L. Landon, INTEC Area Rep.

Max H. Blom  
Max H. Blom, RWMC Area Rep.

Robert L. Johnston  
Robert L. Johnston, RCT Rep.

Matt Chavez  
Matt Chavez, Vice President

**EXHIBIT "A"**  
**WAGE/CLASSIFICATION**

	Effective 4-30-2007	Effective 4-28-2008 3% Increase	Effective 4-27-2009 3% Increase
D&D Skilled Worker	27.68		
D&D Hazardous Reduction Technician	25.00		
D&D Helper	21.65		
IPO Electrician (INTEC)	29.07		
Electrician 1 <sup>st</sup>	27.68		
Electrician 2 <sup>nd</sup>	25.03		
Electrician Helper	21.59		
Instrument Specialist*	29.07		
Instrument 1 <sup>st</sup>	27.68		
Instrument 2 <sup>nd</sup>	25.03		
Instrument Helper	21.59		
Sr. Rad Con Tech	29.43		
Rad Con Tech	26.14		
Jr. Rad Con Tech	21.54		
Analyst Sr.	28.14		
Analyst A	26.16		
Analyst B	23.55		
Analyst C	20.13		
Sr. Dosimetry Tech	24.09		
Dosimetry Tech	21.78		
Assoc. Dosimetry Tech	19.48		
Trainee Dosimetry Tech	17.17		
Spent Nuclear Fuel Sr. Operator	28.83		
Spent Nuclear Fuel Operator	24.83		
Spent Nuclear Fuel Operator Helper	21.41		
Spent Nuclear Fuel Operator Trainee	20.12		
Welder 1 <sup>st</sup> *	26.39		
Welder 2 <sup>nd</sup>	23.74		
Welder Helper	20.30		
Sheet Metal 1 <sup>st</sup> Class*	26.39		
Sheet Metal 2 <sup>nd</sup> Class	23.74		
Sheet Metal Helper	20.30		



**EXHIBIT "A"**  
**WAGE/CLASSIFICATION**

	Effective 4-30-2007	Effective 4-28-2008 3% Increase	Effective 4-27-2009 3% Increase
Mail Labeler	17.86		
Mail Clerk 1 (+18 Months)	17.11		
Mail Clerk 1 (6-18 Months)	14.76		
Mail Clerk Trainee (0-6 Months)	12.48		
Master Photographer	27.17		
Sr. Photographer	25.30		
Photographer	22.91		
Video Producer	27.17		
Videographer	25.30		
Image Processor/Labeler Tech	22.91		
Sr. Printer	22.58		
Printer 2	20.07		
Printer 1	17.53		
Printer Trainee	12.48		

**\*The Instrument Specialist classification, Welder classifications and Sheet Metal classifications will be eliminated once the current employees in those classifications are no longer in those classifications.**

**EXHIBIT “B”  
PROMOTION AND DEMOTION CHARTS**

**Welder  
1/C**

**Sheet  
Metal  
Mech 1/C**

**In the event of a permanent layoff, employees have regression rights to D&D Helper or may elect layoff.**

**EXHIBIT “B”  
PROMOTION AND DEMOTION CHARTS**

**MAINTENANCE (ELECTRICAL)**

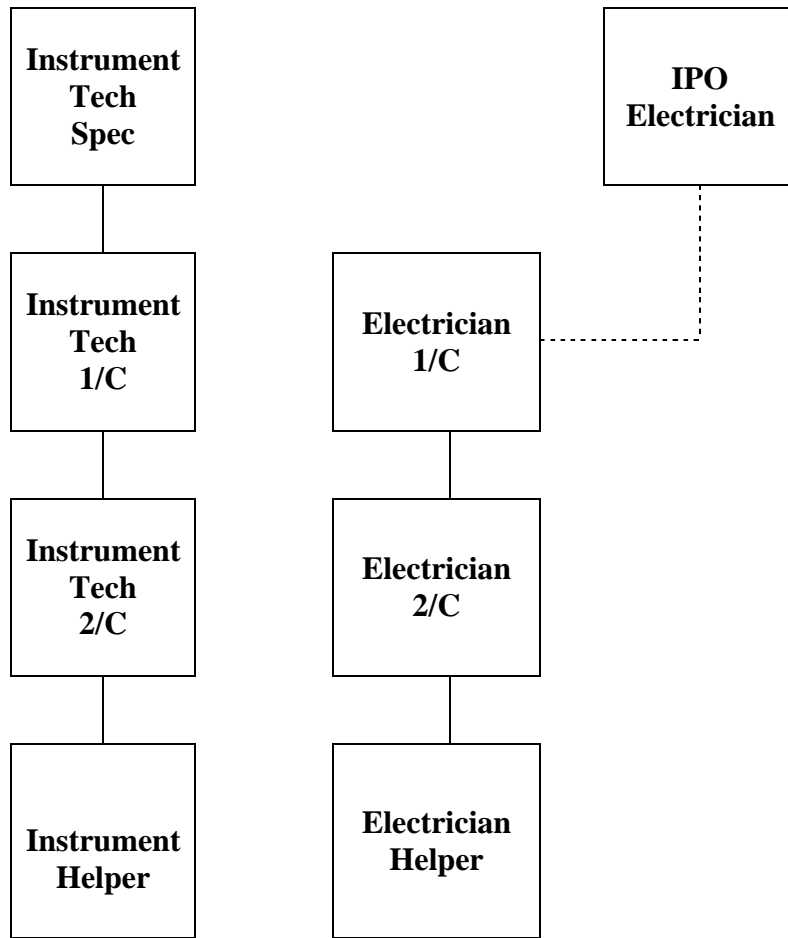

**In the event of a permanent layoff, employees have regression rights to D&D Helper or may elect layoff.**

**EXHIBIT “B”  
PROMOTION AND DEMOTION CHARTS**

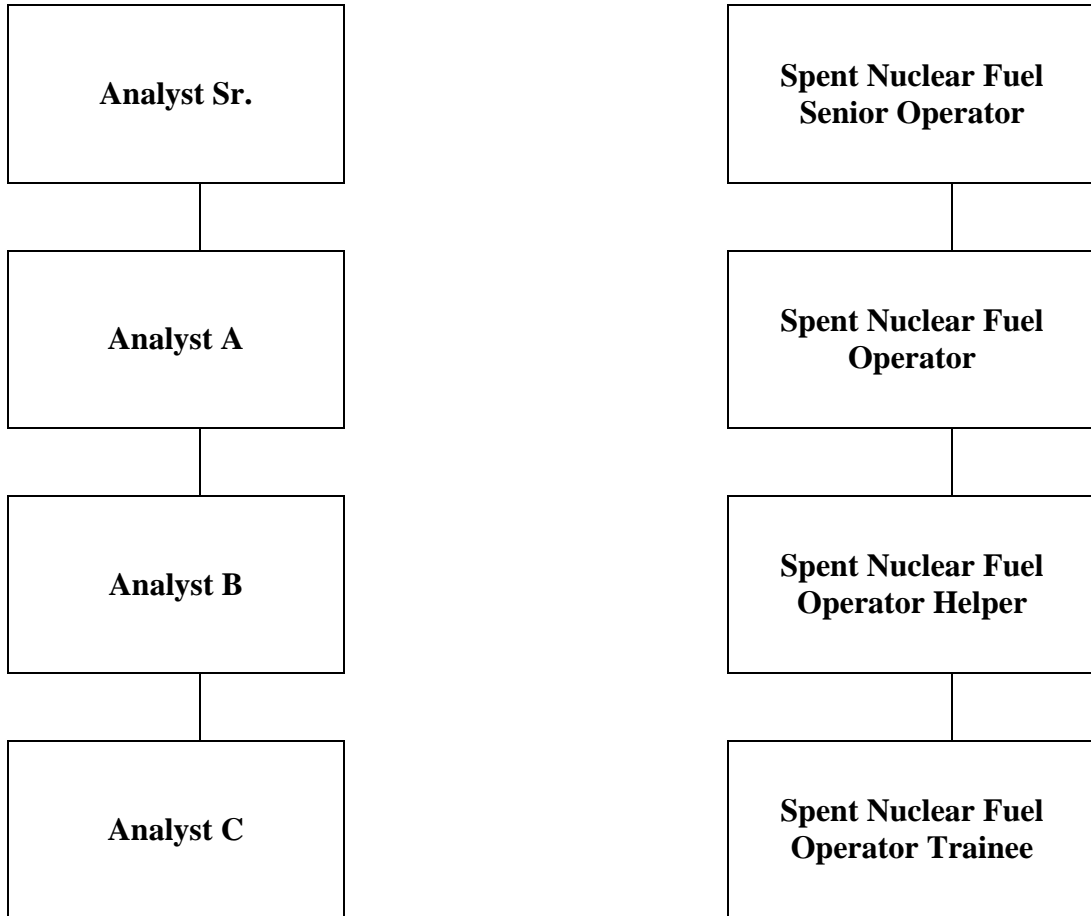

**In the event of a permanent layoff, employees have regression rights to D&D Helper or my elect layoff.**

**EXHIBIT "B"**  
**PROMOTION AND DEMOTION CHARTS**

**PHOTOGRAPHY/ VIDEO**

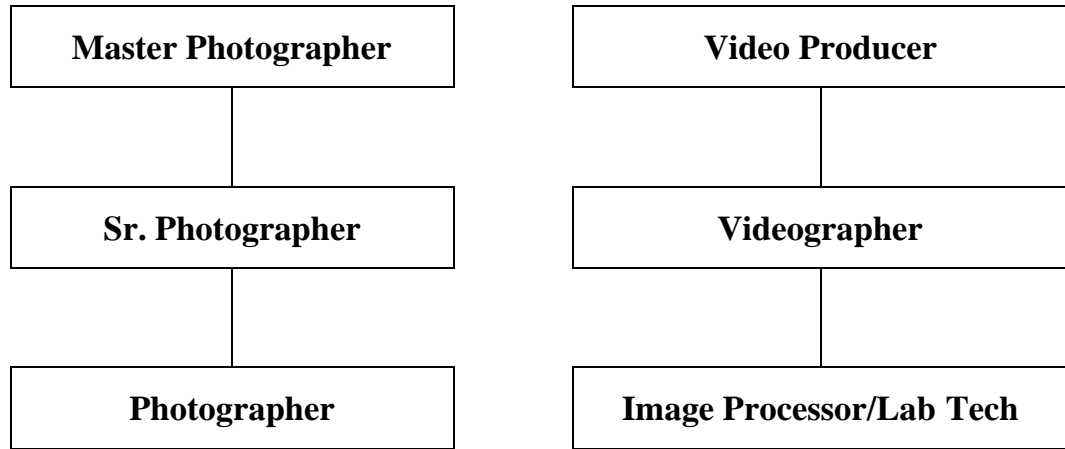

**In the event of a permanent layoff, employees have regression rights to D&D Helper or may elect layoff.**

**EXHIBIT “B”  
PROMOTION AND DEMOTION CHARTS**

**DOSIMETRY**

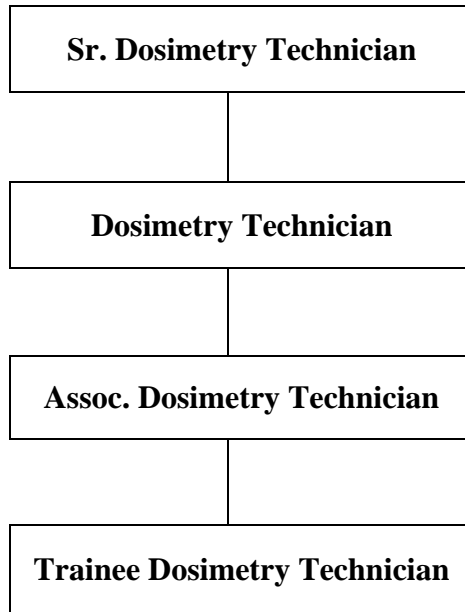

**In the event of a permanent layoff, employees have regression rights to D&D Helper or may elect layoff.**

**EXHIBIT “B”  
PROMOTION AND DEMOTION CHARTS**

**RAD CON**

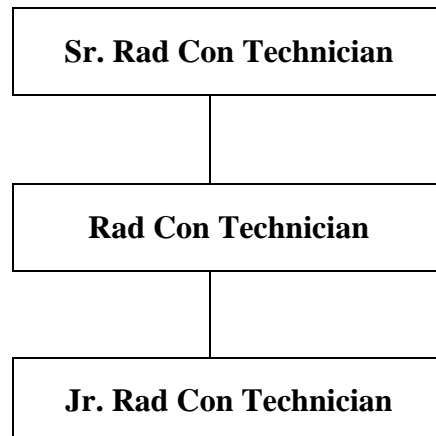

**In the event of a permanent layoff, employees have regression rights to D&D Helper or may elect layoff.**

## **D&D AGREEMENT**

This Agreement applies to CH2M-WG IDAHO, its subcontractors, their subcontractors, assigns or any successful bidding operator, hereafter called the "Company" and the United Steel, Paper and Forestry, Rubber, Manufacturing, Energy, Allied Industrial and Service Workers International Union AFL-CIO Local No. 652, hereinafter referred to as the "Union" and on behalf of those employees comprising the bargaining unit. Unless the Company and the Union mutually agree to the contrary, all provisions of the collective bargaining agreement not specifically modified or in conflict will continue in full force and effect. This Agreement shall apply to all D&D work performed by employees of the Company represented by the Union at the Idaho Site and to all site D&D work which they are assigned by the Company. It's the parties' intention to make every effort to assign tasks relating to cleaning up the facility and reclaiming the Site to "USW Represented Employees" as availability and time permit, unless "construction work" or provisions of the collective bargaining agreement apply.

### **D&D Site Wide Activity**

- D&D activity – generally by project – will have beginning and ending dates.
- D&D designation of a building or area will be by the Company or the client DOE, with prompt notice to the Local Union President.
- Company will accept input from the Union, D&D crews, electrical personnel, and RCT's on the work to be performed and will develop a safe and appropriate plan of action.
- Safety is first. Employees will be assigned work for which they are trained and qualified to perform in a safe manner. If Company and Union deem appropriate, a Union Safety Representative will be assigned.
- Employees who bid D&D will be assigned a position for which they meet the minimum qualifications. The parties agree that job specific and safety training are needed. Training will be provided prior to assignment to a specific task where training is needed. The Company will determine the work shift where required training will be provided. Training grants may be used. Employees who don't bid D&D or with restrictions will be treated in accordance with the collective bargaining agreement.
- A D&D employee may be assigned to any non-D&D classification at any time, in any building or area, as long as they are qualified to safely perform the work. Such employee(s) shall not be assigned as a craftsman outside his craft but may be assigned to assist in other crafts. They will work per contract/job outline with no reduction in pay. D&D employees assigned out of D&D will be brought back on the basis of ability and seniority when new D&D projects or additional workers are needed, before other employees are added temporarily or by bid. An employee may be retained to fill in for an absent employee.
- D&D employees may be assigned or supervised by a Subcontractor or lower tier Subcontractor.



- Lead upgrade - if designated, will be paid \$1.60 per hour above the highest worker assigned to the crew (doesn't include support person) that period.
- Support person-brought in for a specific task covered by their classification-paid additional \$1.00 per hour for hours worked as support. Such \$1.00 per hour shall not be used in the calculation of overtime. Upon completion will return to regular job/shift. The Company will make every effort to consider qualification, seniority, and concerns of the employee, when making support assignments. The job assignments of RCT's and Electrical personnel to D&D building activities are not considered support work.
- D&D crew members will perform all D&D work, within their D&D Classification, which they are qualified and trained to perform safely regardless of jurisdiction. Further, D&D crew members may be assigned to perform any classification of D&D work with no reduction of pay. If the work is of a higher labor grade it will be paid at the higher labor grade. The Company may advance employees within D&D.
- The performance of D&D activity by the D&D crew shall not be considered a violation of the collective bargaining agreement, including Article 4.9 thereof.
- All employees are eligible to bid D&D jobs. The Company will review bidders' seniority, qualifications, work experience and physical fitness, in determining bidder capability and suitability. Full time CWI employees who are represented by USW and are qualified will have priority, prior to CWI hiring from an outside source. If there are not enough bidders, the Company may fill the jobs from any source available.
- Violation of this agreement will be subject to Article XV grievance procedure.
- To promote stability and to increase employment opportunities, the parties agree that all provisions of this Agreement will be interpreted to optimize flexibility in assigning D&D work. The Company will seek written approval from DOE or the appropriate government agency to allow "out-of-year work activities" to be pulled forward, thereby accelerating baseline schedules. If granted, a copy will be provided to Union.
- When D&D operations cease on the site, the RWMC classification will be reinstated unless otherwise agreed.
- The D&D jobs will be established in the M&O Seniority Unit. In the event of a permanent reduction in force in the D&D jobs, the employee(s) displaced may return to their former classification that they held prior to the posting to D&D with/by seniority. A skilled tradesman permanently displaced from his job may fill a job in D&D if qualified. Necessary safety training will be provided.
- The Company and the Union will discuss the skill mix for D&D.
- Employees may be required to wear a respirator/PAPR/APR or pressure suit.

## **D&D Classifications**

- D&D Skilled Trade Worker - \$27.68/hr
- D&D Hazardous Reduction Technician - \$25.00/hr
- D&D Helper - \$21.65/hr

## **The INTEC Area(s) are covered by the D&D Agreement.**

- The Company will continue to accommodate employee's current restrictions in accordance with operational requirements.
- The Welders and Sheet Metal Workers would be eligible for D&D support pay at INTEC only if assigned out of their regular area of work to perform a specific task for/with a D&D work crew. Such employees would be eligible for D&D wage rates only when they are accepted on a future D&D open job.

## **Special Pay Provisions.**

**Guidelines for Pressure Suit Pay.** It is the intent of this guideline to provide premium pay when the nature of the job requires, in addition to clothing normally worn, additional protective clothing prescribed to protect the entire surface of the body and an outside source of breathing air, or self-contained generator for oxygen or air, or a tank of air. The Company shall determine when such equipment is required. When the use of such equipment is required, a premium of three dollars (\$3.00) per hour shall be paid, based on actual hours only, from the time the employee is completely outfitted until such time as the suit is removed. Under normal circumstances, an employee will not be required to work more than four hours in one consecutive period in supplied air from the time the employee is completely outfitted until the time the suit is fully removed. Such three dollars (\$3.00) per hour shall not be used in the calculation of overtime. This guideline is not intended to provide premium pay for performing work in a pressure suit or equivalent equipment when such equipment is required for the protection of the material, not the employee; i.e., the potential risk to the employee would be no greater if he/she performed the job without the pressure suit or special equipment.

**Guidelines for Respirator/PAPR/APR Pay.** When management determines a job requires the use of a respirator/PAPR/APR the employee(s) will be paid fifty cents (.50) per hour for all hours involved and approved by management. Such fifty cents (.50) per hour shall not be used in the calculation of overtime. Employees must be properly certified and keep certified.

## **Duration**

This agreement shall be effective for the term of the existing collective bargaining agreement. The parties agree that should either party request modifications to this agreement due to a substantial change in conditions, or significant administrative problems, the parties will in good faith negotiate on such matters of concern. This agreement may be altered, changed, or amended by mutual agreement of the parties.

## MEMORANDUM OF UNDERSTANDING

Overtime for employees assigned to D&D (actual facility teardown project) will be handled in one of the following methods:

- A) The no preference designation will be eliminated (i.e. volunteers and refusals only on list).

Employee will volunteer weekly by noon on Monday.

The Company will ask employees to work in any order.

A record of hours worked and refused will be kept.

The distribution of overtime will be relatively equal.

If the distribution of overtime is out of spread on a quarterly review (more than 80 hours) highest to lowest, the Company will within thirty (30) days, offer overtime to correct the imbalance. If at the next quarterly review the overtime list is out of spread (more than 80 hours) highest to lowest, the Company will pay those employee(s) that are out of spread at the overtime rate of 1 ½ times their hourly base wage. Other provisions of Article 6 not in conflict will continue in effect.

Other provisions of Article Six not in conflict will continue in effect.

- B) Blanket Overtime: Management will have the option of offering overtime to all employees on an individual project (i.e. RTC). Employees will have the option to turn down the overtime. Under these circumstances overtime hours need not be recorded.

These provisions may not be modified or expanded to cover additional employees without mutual agreement between the Union and the Company.

**Memorandum of Agreement between CH2M-WG Idaho, LLC  
and  
United Steel, Paper and Forestry, Rubber, Manufacturing, Energy,  
Allied Industrial and Service Workers International Union, AFL-CIO  
Local No. 652**

**April 25, 2007 - MOA 01-07**

This MOA addresses those shifts that require seven day-a-week coverage as described in Article 5.3, Work Schedules for Shift Workers.

The Company and the Union agree that in order to fairly address holiday schedules among crews and shift workers who are required by their regular schedule to work Company designated holidays, the following shall apply.

Ten (10) eight hour holidays have been established for these shift workers as described below. The holiday dates will be established annually based on the date of the holiday. On the designated holiday, these shift workers should record eight (8) hours of holiday pay (code 025). All hours worked on a holiday should be recorded as holiday worked and paid at time and one half (X 1 1/2). If these shift workers are assigned to work on a holiday and are approved to be absent, they may record either four (4) hours of PL (code 027), or four (4) hours of unpaid leave (code 030). The hours of unpaid leave are subject to the annual limit of 120 hours.

**Shift Worker Holiday Schedule**

New Year's Day  
Presidents' Day  
Memorial Day  
Independence Day  
Labor Day  
Veterans' Day  
Thanksgiving Day  
Day after Thanksgiving  
Christmas Eve  
Christmas Day

C.W.M.      4-25-07  
For the Company      Date

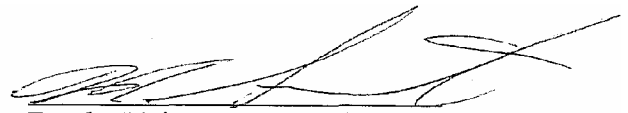
  
For the Union      Date  
4/25/07

CH2M-WG, IDAHO, LLC and UNITED STEEL, PAPER AND FORESTRY, RUBBER, MANUFACTURING, ENERGY, ALLIED-INDUSTRIAL AND SERVICE WORKERS INTERNATIONAL UNION AND Local 652 agree to:

**MOU dated July 1998, Equipment Operator Progression to Heavy Equipment Operator – modified as follow:**

**MOU – Equipment Operator Training**

**4-27-07**

The parties agree to meet within thirty (30) days after the ratification of the working agreement to assign a joint committee to discuss and develop a training plan that will allow for the flexibility and efficiency in improving the potential for an Equipment Operator to receive the necessary training to progress to the Heavy Equipment Operator classification. The Committee's goal is to develop a plan that can be successfully executed within the current and anticipated funding constraints. The training plan will be reviewed annually by the parties to determine its effectiveness and continued use.

ATTACHMENT A

MEMORANDUM OF AGREEMENT

**Between**

**LOCKHEED MARTIN IDAHO TECHNOLOGIES  
COMPANY (LMITCO)**

**and**

**OIL, CHEMICAL AND ATOMIC WORKERS  
INTERNATIONAL UNION (OCAW)**

**June 23, 1998**

**PRIVATIZATION / OUTSOURCING**

The parties recognize that among the primary goals of the Department of Energy (DOE) is to enhance productivity, reduce cost and transition our regional economy from a dependence on federal funding to private industry. Privatization/Outsourcing is one means to accomplish these objectives.

LMITCO, as the INEEL consolidated contractor, has contractual responsibility to take the lead in implementing this program.

The parties also recognize the need to work cooperatively to minimize the impact of privatization/outsourcing on affected employees, the community, and the operation of the INEEL. In this regard, LMITCO will conduct open, forthright, two way communications with affected and potentially affected employees, OCAW representative, and community leaders to develop options for dealing with the impact.

Privatization/outsourcing ("privatization") is defined as the transfer of most, if not all, of a function to the private sector with a goal to transfer people and equipment whereby LMITCO will no longer perform most, if not all, the function with the work remaining in LMITCO's work scope. The following outlines OCAW's involvement as specific functions are identified for privatization.

- **Initial Notification of OCAW**

LMITCO will provide to OCAW on a monthly basis a list of those functions with OCAW-represented employees which LMITCO is considering as privatization candidates. Such list will be confidential until affected employees have been notified by the Company with union presence in the case of OCAW-represented employees. LMITCO will also provide a description of the work to be privatized, the names and classifications of affected OCAW-represented employees, and the projected date of privatization. LMITCO will not submit to OCAW any cost/benefit analysis or send Request for Proposals (RFPs) to potential bidders until the function has been on the list for at least thirty (30) calendar days.

- **Cost/Benefit Analysis**

As part of the cost/benefit analysis, LMITCO will request that DOE-Idaho seek from the Department of labor a wage and benefit determination pursuant to the Service Contract Act (SCA) in accordance with the Department of Labor's normal policies, for positions scheduled to be privatized which are represented by OCAW.

LMITCO's Business Management Branch will present and explain to up to three LMITCO representatives and to two local OCAW representatives and the OCAW International official a cost/benefit analysis of each function considered for privatization which has bargaining unit members represented by OCAW and highlight any variance from the basic cost model. OCAW may appeal within fifteen (15) calendar days any variance from the basic cost/benefit analysis model to DOE-ID and then DOE-HQ for a final decision provided such appeal to DOE-HQ is submitted in writing to DOE-HQ within 10 calendar days of receipt of the decision from DOE-ID. As an alternative, OCAW may choose to arbitrate any variance through the expedited arbitration procedure. Cost benefit analysis data will only be disclosed to union officials and representatives who have a need to know such data in the exercise of their Union responsibilities and who have signed the attached non-disclosure agreement provided by LMITCO. Open discussions will be held with OCAW officials regarding the analysis and any response by such officials will be fully considered. OCAW officials may request, and LMITCO will not decline to provide, relevant information such as the documentation supporting the cost/benefit analysis. Discussions between LMITCO and OCAW officials will occur as needed, during the thirty (30) calendar-day period triggered by LMITCO'S Business Management Branch's presentation to OCAW and LMITCO representatives of the cost/benefit analysis. OCAW officials may present to LMITCO any alternative, including a proposed method to determine the numbers of employees necessary for the effective performance of any privatized work for consideration during this thirty (30) calendar-day period.

- **Request for Proposal (RFP) Decision**

All input received from OCAW officials and others will be reviewed by LMITCO management having final decision-making authority. Such input will be given consideration prior to any final decision by LMITCO to send out and RFP. LMITCO has final authority regarding any privatization decision.

Selection is subject to the following criterion:

A minimum cost savings threshold of an average of 5% per year over the period of the LMITCO/contractor contract.

- **RFP Process**

OCAW officials will receive a copy of the RFP within seven (7) calendar days after LMITCO has made a decision to send out RFP's and finalized the RFP's and prior to such RFP's being sent to potential bidders. OCAW officials must provide input to LMITCO within fifteen (15) calendar days of receiving the RFP. LMITCO will consider any such input prior to sending out the RFP. LMITCO will review all responses to RFP's received and has final authority to select the successful bidder, consistent with the terms of the RFP. LMITCO will not arbitrarily or unreasonably reject any alternative previously proposed by the union.

The RFP shall provide that for the first year of the contract, or the expiration of LMITCO/OCAW contract (whichever comes first), employees performing SCA-covered privatized work shall receive equivalent base wages (including any applicable shift differentials) and comparable benefits to those paid by LMITCO during an employee's preceding year with LMITCO from whatever source(s). Beginning with the second year of the contract, or the expiration of the LMITCO/OCAW contract (whichever comes first), such employees will be paid under the subcontract at least the prevailing wages and benefits as provided by the wage determination or in accordance with any negotiated collective bargaining agreement, as applicable.

The determination of successor ship issues should be decided in accordance with the established rules developed under the NLRA; each case of privatization/outsourcing will be addressed on its own facts. The parties will endeavor to structure any outsourcing so that current INEEL workers hired to perform outsourced work comprise a separate bargaining unit within the meaning of the NLRA.

- **Affected Employees**

To the extent that a contractor must supplement its existing work force, affected OCAW-represented employees (those in the function to be privatized) will be offered employment for such openings for the scope of work formerly performed by such employees in accordance with the following priority:

Employees performing the same work and requiring the same skills for LMITCO at the time of transition as is required by the contractor, e.g. carpenter work, shall be made offers for such openings in line with INEEL site seniority.

Employees not performing the same work for LMITCO at the time of transition as is required by the contractor but nevertheless qualified shall be made offers for such openings in line with INEEL site seniority.

Qualified individuals on the "3161" list (see Memorandum of Agreement regarding Preference) in the line with INEEL seniority.

An affected employee shall not be deemed unqualified for a position within the applicable scope of work if the employee is qualifiable for that position between one month after the contractor has won the bid and the scheduled date the contractor assumes the work. (Employee must be qualifiable within 90 calendar days regardless of the above). Any training required for the affected employees to be qualified by the scheduled date shall be provided by LMITCO or the contractor on paid time, to be scheduled at the convenience of LMITCO.

The contractor shall not make offers of employment under the contract other than to affected employees and qualified individuals on the 3161 list for openings in the scope of work formerly performed by such affected employees and individuals on the 3161 list currently at LMITCO until all affected employees and individuals on the 3161 list qualified for such positions have been given job offers by the contractor.

If the successful bidder increases the number of positions or vacancies occur under the contract within six (6) months after operations begin, its obligation to offer employment to qualified affected employees and qualified individuals on the 3161 list shall continue until the additional positions are filled. The contractor shall, as soon as possible, notify and solicit applications from affected employees and qualified individuals on the 3161 list who shall be given a reasonable period within which to accept such offers, which in no case shall be less than ten (10) calendar days.



Employees in the function to be privatized may refuse to accept a job offer from the successful bidder. Employees not hired by the successful bidder will be considered for any LMITCO openings for which they are qualified or qualifiable within ninety (90) calendar days prior to any layoff which may occur. LMITCO will provide such training. Any such employee refusing to be trained for a LMITCO opening shall be considered to have voluntarily terminated. If no openings for which the employee is qualified or qualifiable within ninety (90) calendar days exist, the employee will be laid off in accordance with the bargaining unit Agreement. LMITCO will comply with applicable laws during any layoff process including providing preference for eligible employees in accordance with applicable provisions of Section 3161 of the National Defense Authorization Act.

The parties agree that costs associated with the up to 90 day period employees affected by privatization have to become qualified for available openings prior to layoffs shall not be part of the cost/benefit analysis model. An “available opening” exists from the time Human Resources has received an approved Employee Position Description (EPD) to the time an individual has received and accepted an offer or the EPD has been cancelled by management.

An affected employee involuntarily laid off (not for cause) by the winning bidder during the first year of the contract shall be considered for LMITCO openings for which such employee is qualified. If the employee cannot be placed with LMITCO, the employee will be placed on the recall list to those classifications to which the employee would have been on recall if eligible had the employee been laid off from LMITCO rather than hired by the contractor, or the 3161 list. The length of time on recall shall start as if the employee were laid off at the time the employee was hired by the contractor. During the period on the recall or 3161 list, the affected employee will receive payment by the winning bidder equal to Two Thousand (\$2,000.00) Dollars per month for each month left in the first year of employment. Payment will cease upon receiving a job offer from LMITCO or a job offer of equivalent wages and comparable, if not equivalent, benefits from another employer.

LMITCO will attempt to mitigate the impact of privatization on its employees by encouraging bidders to hire LMITCO employees and/or discouraging the successful bidder from laying off former LMITCO employees during their first months of employment.

## **Arbitration**

### **Procedure**

For an alleged violation of the agreement, the parties have agreed to an expedited arbitration procedure during which time is of the essence. Grievances over the applicability of Attachment A shall be subject to the expedited arbitration procedure. The procedure is as follows:

Immediately after ratification of the labor agreement, the parties shall request from the Federal Mediation and Conciliation Service (FMCS) a list of forty (40) arbitrators from the states of Idaho, Utah, Montana, Wyoming, Arizona, Nevada, New Mexico, and Colorado.

Upon receipt of the list from the FMCS, the parties shall immediately jointly contact each of the arbitrators to determine those willing to commit to be available for a hearing within thirty(30) days of being contacted for three (3) consecutive business days, and will render an award within two (2) weeks of receiving briefs from the parties.

From a pool of those arbitrators who meet all the criteria above, nine (9) shall be selected with the parties striking alternately from the list of qualifying arbitrators (with a coin toss determining who strikes first).

Upon a grievance being filed within seven (7) calendar days after the Company has sent out the RFP's the parties shall jointly request FMCS assistance for mediation and telephonically contact each of the nine (9) pool arbitrators to determine who is available for a hearing within thirty (30) calendar days for three (3) consecutive days. The parties shall alternately strike names of arbitrators (with a coin toss determining who strikes first) from the list of available arbitrators until only one is left who shall be the arbitrator to hear and decide the case.

The parties shall repeat biennially (once every two years) the selection process to determine the pool of nine (9) arbitrators.

The Company and the Union may each strike one (1) arbitrator from the pool during each year,

The parties shall be allowed to submit briefs to the arbitrator. Such briefs must be submitted within one (1) week of the last day of the arbitrator hearing. No extensions for briefs shall be granted. A brief not submitted in a timely manner shall not be considered by the arbitrator.

An arbitrator must render an award within two (2) weeks of receiving the briefs.

If the parties have not selected the panel of nine (9) arbitrators when the Union first files a grievance, the Company and the Union shall mutually agree on an arbitrator or select and arbitrator in accordance with the procedure in the labor agreement.

It is understood that the fees and expenses of the arbitrator shall be an allowable cost under the DOE-LMITCO contract in any arbitration occurring under this agreement. Court reporter and transcript costs for LMITCO and OCAW shall be paid in accordance with the Memorandum of Agreement regarding Court Reporter/Transcripts.

**Other Resolutions**

Issues resolved through an appeal through DOE are not arbitrable.

- The Union must file a grievance within seven (7) calendar days from the date the Company sends out RFP's to grieve any arbitrable issue involving the various privatization process steps up to the time the Company sends out the RFP.
- The Union must file a grievance within seven (7) calendar days from the date the Union is notified of the selection of the winning bidder to grieve whether the selected bidder met the RFP selection criteria.
- The Company agrees not to transition the affected employees and function to the winning bidder until at least 90 days after it has sent out the RFP's.
- If LMITCO decides to bring back a function previously privatized, then all previous LMITCO employees employed by the privatization entity at the time of such decision shall be offered positions with LMITCO in the functions.

The parties agree to work together to ensure an efficient implementation of LMITCO privatization initiatives.

This agreement shall expire on the expiration date of the current labor agreement.

E. B. Tuz 8/12/98  
LMITCO Representative Date

J.H. De Detenacion 8-12-98  
OCAW Local 2-652 Representative Date

James Helzer 8/12/98  
OCAW International Representative Date

MEMORANDUM OF AGREEMENT

Between

LOCKHEED MARTIN IDAHO TECHNOLOGIES COMPANY  
(LMITCO)

and

OIL, CHEMICAL AND ATOMIC WORKERS  
INTERNATIONAL UNION (OCAW)

June 23, 1998

COURT REPORTER/TRANSCRIPTS

This will confirm the following understanding reached among DOE, OCAW and Lockheed Martin Idaho Technologies Company officials in regard to court reporter and transcript costs for any arbitration occurring under the terms of Attachment A (The Memorandum of Agreement on Privatization/Outsourcing).

- The party requesting a court reporter will bear the cost of the court reporter services.
- The party requesting a court reporter will pay for the first copy of the transcript (record) if the party wants a transcript.
- Court reporter costs and transcripts (record) costs shall not be deemed allowable cost to the Company up to a total of \$35,000 a year. Reimbursement of such costs to OCAW will be governed by OCAW's agreement with DOE.
- Subject to the availability of appropriations, in the event the Union incurs costs and transcript (record) costs in excess of \$35,000 in any year in connection with such arbitration, DOE agrees to reimburse the Union for such excess costs. Such reimbursement may be made through LMITCO.

E. B. [Signature]  
Lockheed Martin Idaho Technologies Company

8/12/98  
Date

[Signature]  
OCAW International

8/12/98  
Date

D. V. [Signature]  
OCAW Local 2-652

8-12-98  
Date

**2007****January**

S	M	T	W	T	F	S
	1	2	3	4	5	6
7	8	9	10	11	12	13
14	15	16	17	18	19	20
21	22	23	24	25	26	27
28	29	30	31			

**February**

S	M	T	W	T	F	S
				1	2	3
4	5	6	7	8	9	10
11	12	13	14	15	16	17
18	19	20	21	22	23	24
25	26	27	28			

**March**

S	M	T	W	T	F	S
				1	2	3
4	5	6	7	8	9	10
11	12	13	14	15	16	17
18	19	20	21	22	23	24
25	26	27	28	29	30	31

**April**

S	M	T	W	T	F	S
1	2	3	4	5	6	7
8	9	10	11	12	13	14
15	16	17	18	19	20	21
22	23	24	25	26	27	28
29	30					

**May**

S	M	T	W	T	F	S
		1	2	3	4	5
6	7	8	9	10	11	12
13	14	15	16	17	18	19
20	21	22	23	24	25	26
27	28	29	30	31		

**June**

S	M	T	W	T	F	S
					1	2
3	4	5	6	7	8	9
10	11	12	13	14	15	16
17	18	19	20	21	22	23
24	25	26	27	28	29	30

**July**

S	M	T	W	T	F	S
1	2	3	4	5	6	7
8	9	10	11	12	13	14
15	16	17	18	19	20	21
22	23	24	25	26	27	28
29	30	31				

**August**

S	M	T	W	T	F	S
			1	2	3	4
5	6	7	8	9	10	11
12	13	14	15	16	17	18
19	20	21	22	23	24	25
26	27	28	29	30	31	

**September**

S	M	T	W	T	F	S
						1
2	3	4	5	6	7	8
9	10	11	12	13	14	15
16	17	18	19	20	21	22
23	24	25	26	27	28	29
30						

**October**

S	M	T	W	T	F	S
	1	2	3	4	5	6
7	8	9	10	11	12	13
14	15	16	17	18	19	20
21	22	23	24	25	26	27
28	29	30	31			

**November**

S	M	T	W	T	F	S
				1	2	3
4	5	6	7	8	9	10
11	12	13	14	15	16	17
18	19	20	21	22	23	24
25	26	27	28	29	30	

**December**

S	M	T	W	T	F	S
						1
2	3	4	5	6	7	8
9	10	11	12	13	14	15
16	17	18	19	20	21	22
23	24	25	26	27	28	29
30	31					

**2008*****January***

S	M	T	W	T	F	S
		1	2	3	4	5
6	7	8	9	10	11	12
13	14	15	16	17	18	19
20	21	22	23	24	25	26
27	28	29	30	31		

***February***

S	M	T	W	T	F	S
					1	2
3	4	5	6	7	8	9
10	11	12	13	14	15	16
17	18	19	20	21	22	23
24	25	26	27	28	29	

***March***

S	M	T	W	T	F	S
						1
2	3	4	5	6	7	8
9	10	11	12	13	14	15
16	17	18	19	20	21	22
23	24	25	26	27	28	29
30	31					

***April***

S	M	T	W	T	F	S
		1	2	3	4	5
6	7	8	9	10	11	12
13	14	15	16	17	18	19
20	21	22	23	24	25	26
27	28	29	30			

***May***

S	M	T	W	T	F	S
				1	2	3
4	5	6	7	8	9	10
11	12	13	14	15	16	17
18	19	20	21	22	23	24
25	26	27	28	29	30	31

***June***

S	M	T	W	T	F	S
1	2	3	4	5	6	7
8	9	10	11	12	13	14
15	16	17	18	19	20	21
22	23	24	25	26	27	28
29	30					

***July***

S	M	T	W	T	F	S
		1	2	3	4	5
6	7	8	9	10	11	12
13	14	15	16	17	18	19
20	21	22	23	24	25	26
27	28	29	30	31		

***August***

S	M	T	W	T	F	S
					1	2
3	4	5	6	7	8	9
10	11	12	13	14	15	16
17	18	19	20	21	22	23
24	25	26	27	28	29	30
31						

***September***

S	M	T	W	T	F	S
	1	2	3	4	5	6
7	8	9	10	11	12	13
14	15	16	17	18	19	20
21	22	23	24	25	26	27
28	29	30				

***October***

S	M	T	W	T	F	S
			1	2	3	4
5	6	7	8	9	10	11
12	13	14	15	16	17	18
19	20	21	22	23	24	25
26	27	28	29	30	31	

***November***

S	M	T	W	T	F	S
						1
2	3	4	5	6	7	8
9	10	11	12	13	14	15
16	17	18	19	20	21	22
23	24	25	26	27	28	29
30						

***December***

S	M	T	W	T	F	S
	1	2	3	4	5	6
7	8	9	10	11	12	13
14	15	16	17	18	19	20
21	22	23	24	25	26	27
28	29	30	31			

**2009**

***January***

S	M	T	W	T	F	S
				1	2	3
4	5	6	7	8	9	10
11	12	13	14	15	16	17
18	19	20	21	22	23	24
25	26	27	28	29	30	31

***February***

S	M	T	W	T	F	S
1	2	3	4	5	6	7
8	9	10	11	12	13	14
15	16	17	18	19	20	21
22	23	24	25	26	27	28

***March***

S	M	T	W	T	F	S
1	2	3	4	5	6	7
8	9	10	11	12	13	14
15	16	17	18	19	20	21
22	23	24	25	26	27	28
29	30	31				

***April***

S	M	T	W	T	F	S
			1	2	3	4
5	6	7	8	9	10	11
12	13	14	15	16	17	18
19	20	21	22	23	24	25
26	27	28	29	30		

***May***

S	M	T	W	T	F	S
					1	2
3	4	5	6	7	8	9
10	11	12	13	14	15	16
17	18	19	20	21	22	23
24	25	26	27	28	29	30
31						

***June***

S	M	T	W	T	F	S
	1	2	3	4	5	6
7	8	9	10	11	12	13
14	15	16	17	18	19	20
21	22	23	24	25	26	27
28	29	30				

***July***

S	M	T	W	T	F	S
			1	2	3	4
5	6	7	8	9	10	11
12	13	14	15	16	17	18
19	20	21	22	23	24	25
26	27	28	29	30	31	

***August***

S	M	T	W	T	F	S
						1
2	3	4	5	6	7	8
9	10	11	12	13	14	15
16	17	18	19	20	21	22
23	24	25	26	27	28	29
30	31					

***September***

S	M	T	W	T	F	S
		1	2	3	4	5
6	7	8	9	10	11	12
13	14	15	16	17	18	19
20	21	22	23	24	25	26
27	28	29	30			

***October***

S	M	T	W	T	F	S
				1	2	3
4	5	6	7	8	9	10
11	12	13	14	15	16	17
18	19	20	21	22	23	24
25	26	27	28	29	30	31

***November***

S	M	T	W	T	F	S
1	2	3	4	5	6	7
8	9	10	11	12	13	14
15	16	17	18	19	20	21
22	23	24	25	26	27	28
29	30					

***December***

S	M	T	W	T	F	S
		1	2	3	4	5
6	7	8	9	10	11	12
13	14	15	16	17	18	19
20	21	22	23	24	25	26
27	28	29	30	31		

**2010****January**

S	M	T	W	T	F	S
					1	2
3	4	5	6	7	8	9
10	11	12	13	14	15	16
17	18	19	20	21	22	23
24	25	26	27	28	29	30
31						

**February**

S	M	T	W	T	F	S
	1	2	3	4	5	6
7	8	9	10	11	12	13
14	15	16	17	18	19	20
21	22	23	24	25	26	27
28						

**March**

S	M	T	W	T	F	S
	1	2	3	4	5	6
7	8	9	10	11	12	13
14	15	16	17	18	19	20
21	22	23	24	25	26	27
28	29	30	31			

**April**

S	M	T	W	T	F	S
				1	2	3
4	5	6	7	8	9	10
11	12	13	14	15	16	17
18	19	20	21	22	23	24
25	26	27	28	29	30	

**May**

S	M	T	W	T	F	S
						1
2	3	4	5	6	7	8
9	10	11	12	13	14	15
16	17	18	19	20	21	22
23	24	25	26	27	28	29
30	31					

**June**

S	M	T	W	T	F	S
		1	2	3	4	5
6	7	8	9	10	11	12
13	14	15	16	17	18	19
20	21	22	23	24	25	26
27	28	29	30			

**July**

S	M	T	W	T	F	S
				1	2	3
4	5	6	7	8	9	10
11	12	13	14	15	16	17
18	19	20	21	22	23	24
25	26	27	28	29	30	31

**August**

S	M	T	W	T	F	S
1	2	3	4	5	6	7
8	9	10	11	12	13	14
15	16	17	18	19	20	21
22	23	24	25	26	27	28
29	30	31				

**September**

S	M	T	W	T	F	S
			1	2	3	4
5	6	7	8	9	10	11
12	13	14	15	16	17	18
19	20	21	22	23	24	25
26	27	28	29	30		

**October**

S	M	T	W	T	F	S
					1	2
3	4	5	6	7	8	9
10	11	12	13	14	15	16
17	18	19	20	21	22	23
24	25	26	27	28	29	30
31						

**November**

S	M	T	W	T	F	S
	1	2	3	4	5	6
7	8	9	10	11	12	13
14	15	16	17	18	19	20
21	22	23	24	25	26	27
28	29	30				

**December**

S	M	T	W	T	F	S
			1	2	3	4
5	6	7	8	9	10	11
12	13	14	15	16	17	18
19	20	21	22	23	24	25
26	27	28	29	30	31	



# **NOTES**